

# 2 Kirmesbuden



2 fairground booths  
2 stands forains  
2 kermiskramen

Art. Nr. 140446

- D**
- Vor Beginn des Bastelns sollten Sie sich mit den Spritzlingen und der Anleitung vertraut machen.
  - Sollte es einmal vorkommen, dass ein Teil im Bausatz fehlt, kreuzen Sie bitte das fehlende Teil in der Anleitung an und schicken Sie diese bitte an Fa. Gebr. FALLER GmbH, Abt. Kundendienst, Kreuzstraße 9, 78148 Gütenbach. Sie erhalten dann umgehend Ersatz.
  - **In diesem Bausatz sind einige Kunststoffteile übrig.**
- GB**
- Before beginning with the assembly please familiarize yourself with the parts and read the instructions carefully.
  - In case of missing parts please indicate these on the instructions leaflet with a circle and return the leaflet to Gebr. FALLER GmbH, Kreuzstraße 9, D-78148 Gütenbach, Germany. You will receive the replacement by return.
  - **Some of the parts in this box are not needed to construct the model.**
- F**
- Avant de commencer le montage de votre maquette bien lire la notice et repérer les grappes.
  - Si une pièce manque dans une boîte, cochez la pièce correspondante sur la notice et renvoyez-la-nous à Gebr. FALLER GmbH, Kreuzstraße 9, D-78148 Gütenbach (R.F.A.). Nous vous ferons parvenir la pièce par retour.
  - **Dans cette boîte se trouvent quelques pièces qui ne seront pas utilisées pour le montage.**
- NL**
- Vóór het bouwen zou men de gietstukken en de handleiding moeten bestuderen.
  - Indien onverhoopt een onderdeel aan het bouwpakket ontbreekt, gelieve men het ontbrekende deel in de handleiding aan te kruisen en deze te zenden aan Gebr. FALLER GmbH, Kreuzstraße 9, D-78148 Gütenbach. U ontvangt dan omgaand en gratis het ontbrekende onderdeel.
  - **Van dit bouwpakket worden enkele kunststof delen niet gebruikt.**

Für den Zusammenbau des Modells empfehlen wir folgende FALLER-Artikel (sind nicht im Bausatz enthalten):  
For the assembly of the kit we recommend following FALLER products (not included in the kit):  
Pour l'assemblage du modèle, nous vous recommandons les articles FALLER suivants (non inclus dans le kit):  
Om dit model te bouwen adviseren wij de volgende FALLER producten (maken geen deel uit van deze bouwset):



Art. Nr. 170492  
FALLER-EXPERT

Flüssigkleber in Plastikflasche mit Spezialkanüle für feinste Klebstoffdosierung.

FALLER-EXPERT

Liquid cement in plastic bottle with canule for very fine dosage.

FALLER-EXPERT

Colle liquide en bouteille plastique avec bec verseur pour un dosage précis.

FALLER-EXPERT

Vloeibare lijm in plastic-flacon met doserbuisje om nauwkeurig te lijmen.



Art. Nr. 170688  
Spezial-Seitenschneider  
zum gratfreien Abtrennen von feinsten Spritzteilen.  
Nur für Polystyrol geeignet.

Special side cutter  
for cutting off ultra-fine moulded parts without burrs.  
Only suitable for polystyrene.

Pince coupante spéciale  
pour couper sans bavure les pièces miniatures moulées par injection.  
Convient uniquement au polystyrène.

Speciale zijknijptang  
voor het braamloos afknippen van de fijnste gietstukdelen.  
Alleen geschikt voor polystyrol.

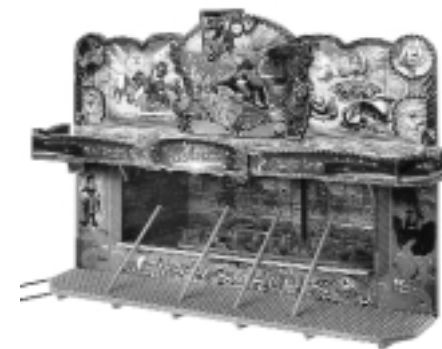

Inhalt	Spritzlinge	1B	2 x	3	3 x
Contents	Sprues	2A	1 x	4	1 x
Contenu	Moulages	2B	1 x	5	3 x
Inhoud	Gietstukken				

Stromverbrauch:

Current consumption:

Consummation de courant:

Stroomverbruik:



2 x 35 mA

Art.180671

Sa. Nr. 147 924 0

2

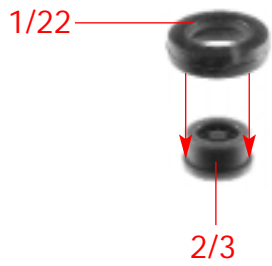

**(A)** 4 x

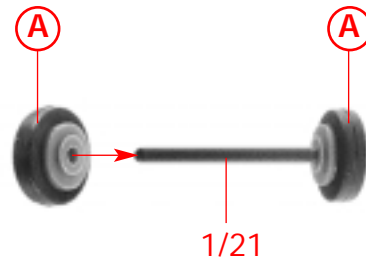

**(B)** 2 x

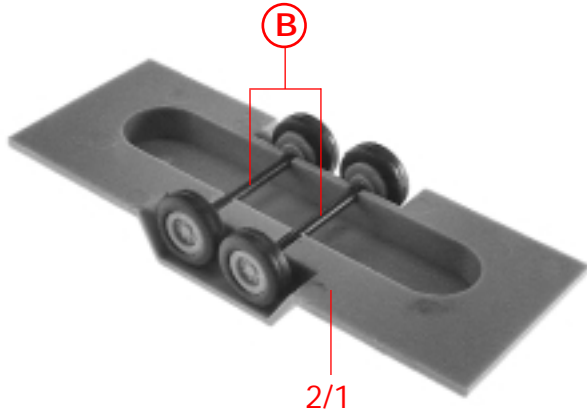

**(C)**

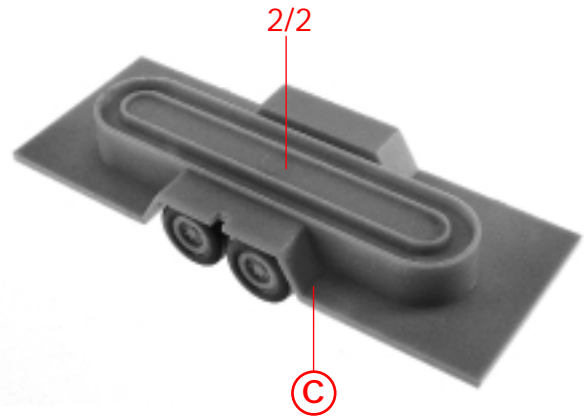

**(D)**

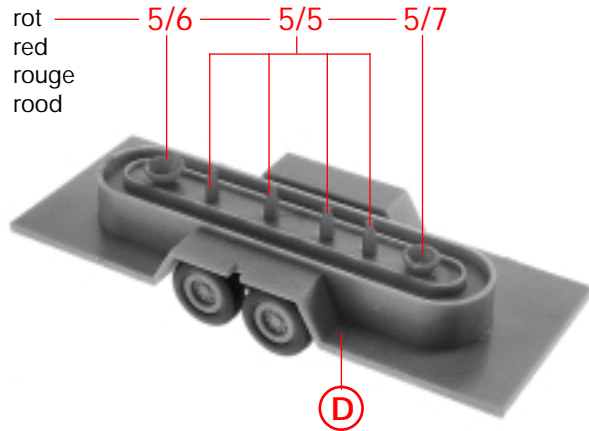

**(E)**

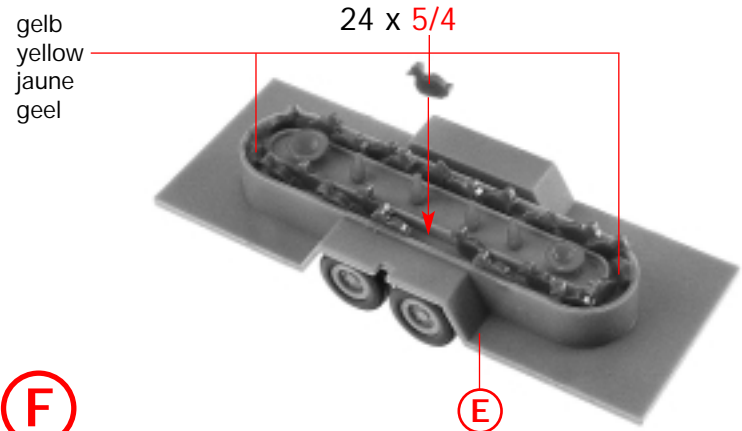

**(F)**

In einen flachen Teller eine Lauge aus Wasser und 2 Tropfen Spülmittel ansetzen. Schutzpapier entfernen und das Deco mit einem Pinsel auf der Klebeseite mit Lauge benetzen. Entsprechende Teile ebenfalls mit der Lauge benetzen. Mit einer Gummiwalze oder einem weichen Tuch das Wasser unter der Folie ausstreichen. Gut trocknen lassen.

On a flat plate prepare a solution consisting of water and two drops of a dish washing liquid. Remove the liner and wet the adhesive side of the decoration sheet with that solution using a paintbrush. Also wet the corresponding parts with the solution. Squeeze the water out from beneath the sheet using a rubber cylinder or a soft cloth. Allow to dry thoroughly.

Sur une assiette plate, préparer une solution composée d'eau et de 2 gouttes d'un produit pour la vaisselle. Détacher le papier protecteur et mouiller de cette solution le côté gommé de la feuille de décoration, à l'aide d'un pinceau. Mouiller également de cette solution les pièces correspondantes. En pressant à l'aide d'un rouleau en caoutchouc ou d'un chiffon doux, éliminer l'eau se trouvant sous la feuille. Bien laisser sécher.

Maak in een plat schaaltje een sopje van water en 2 druppels afwasmiddel. Verwijder het bescherm papier en bevochtig de plakzijde van het decoratie-element met behulp van een penseel met het sopje. Bevochtig de overeenkomende delen eveneens met het sopje. Strijk met een rubberwals of een zachte doek het water onder de folie vandaan. Laat het geheel goed drogen.

Deco 7

Deco 8

Deco 27

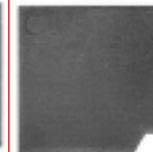
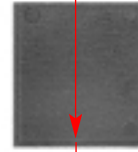
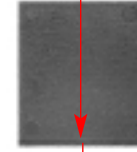
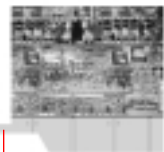
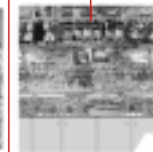

**G** 4/3

**H** 4/2

**I** 4/1

Deco 34

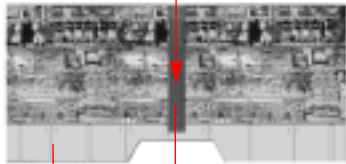

**J** **I** 4/37

**G**

**H**

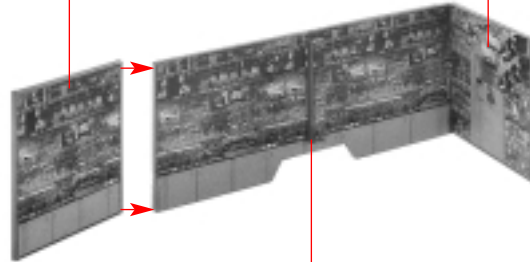

**K** **J**

**K**

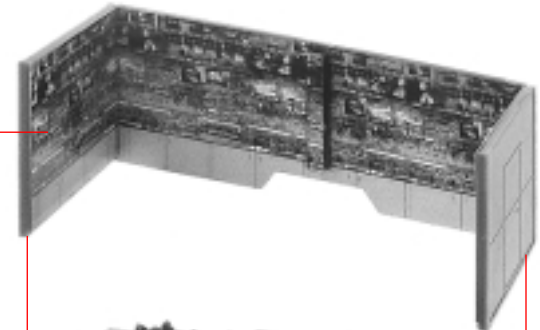

**L** **F**



4

Deco 26

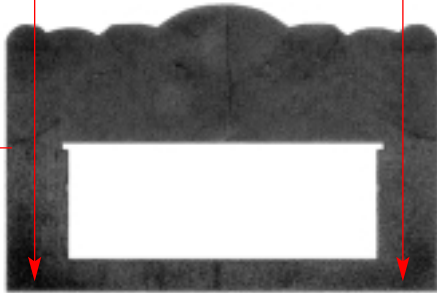

4/5

(M)

Deco 9

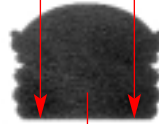
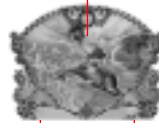

4/7

(N)

(N)

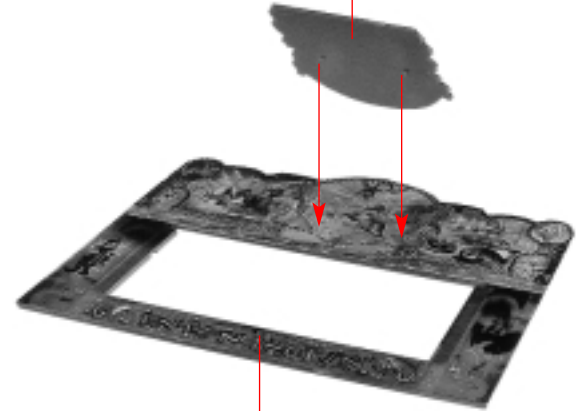

(O)

(M)

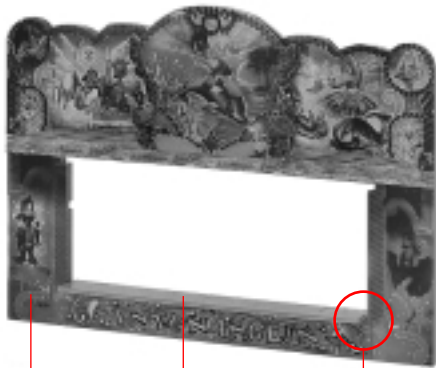

(P)

(O)

2/4



(P)

(L)

(Q)

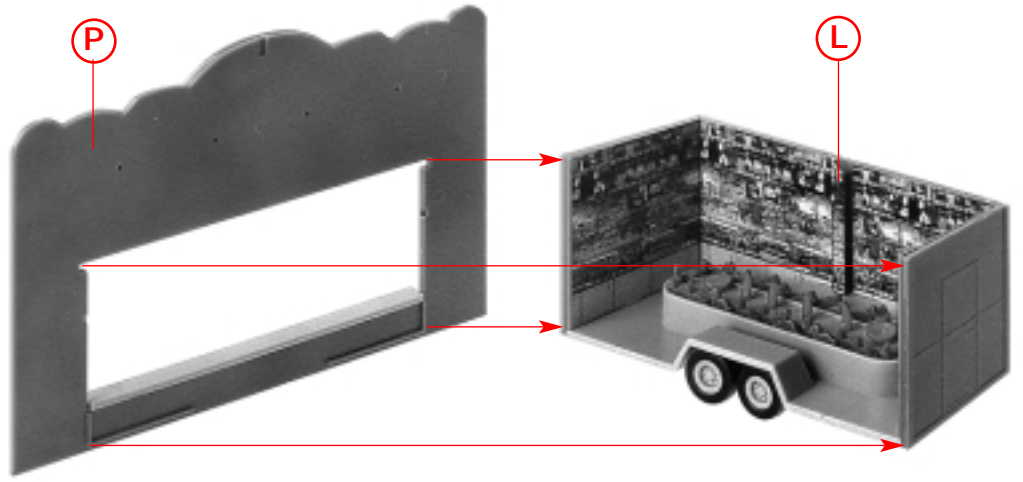

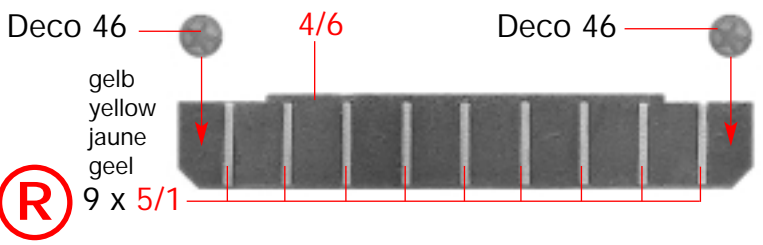

(R)

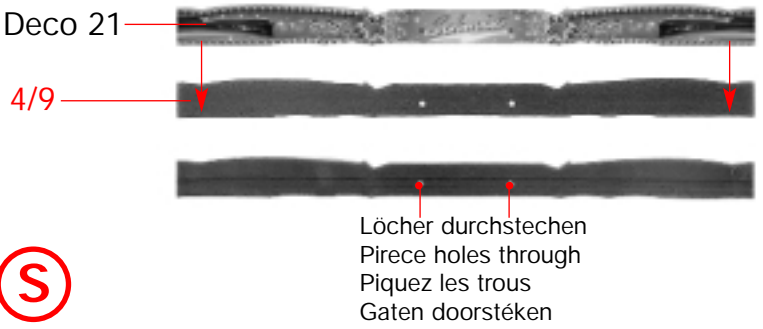

(S)

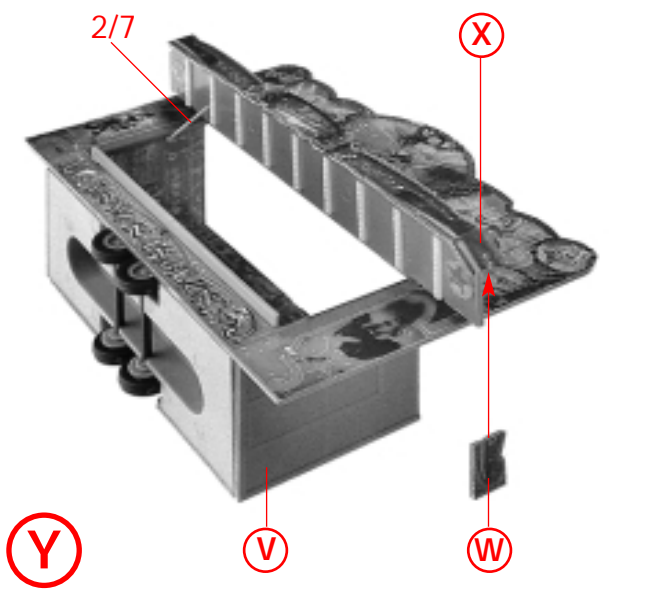
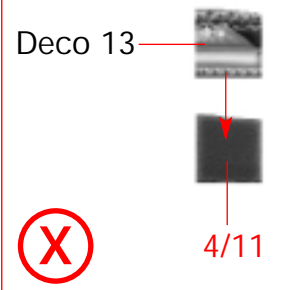
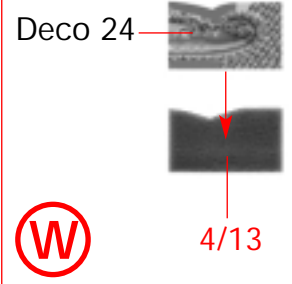
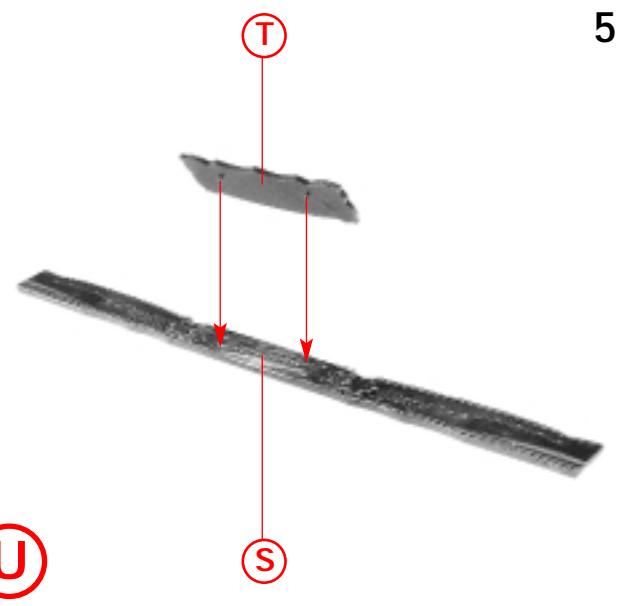
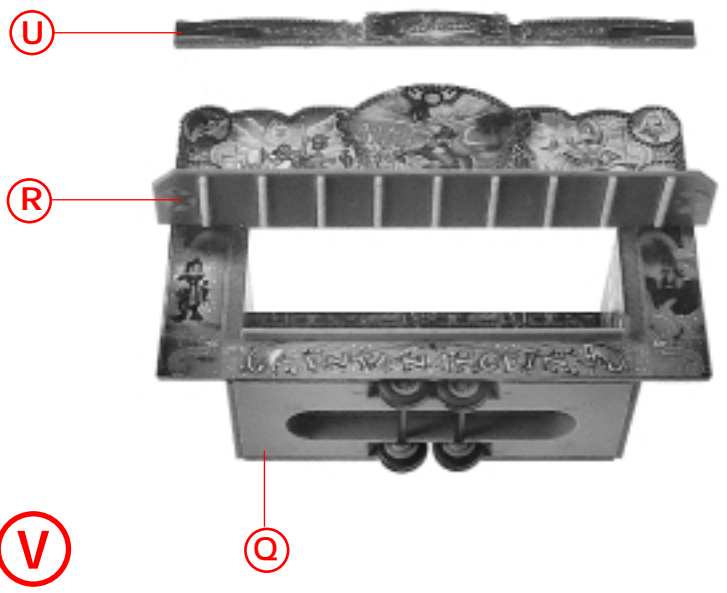

6

Deco 47 2/10

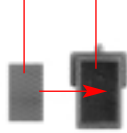

(a)

Deco 12



4/10

Deco 25



4/12

(c)

(b)

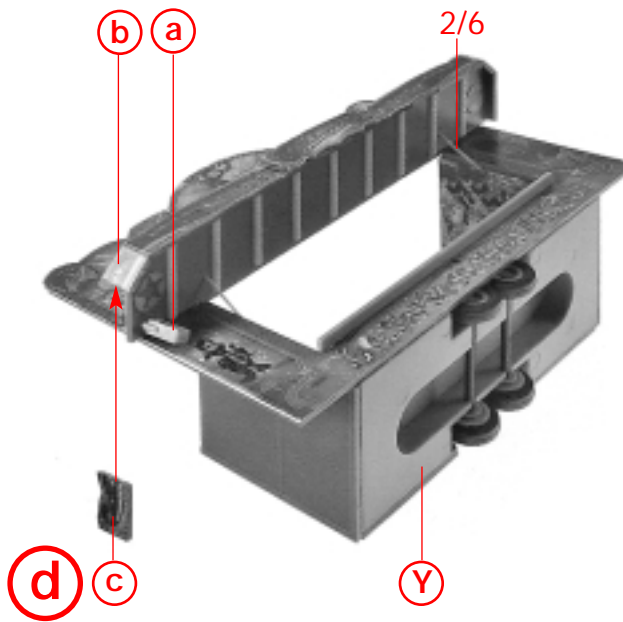

(d)

(c)

(Y)

Art.-Nr. 180671  
liegt nicht bei  
not included  
non jointe  
niet bijgevoegd

(e)

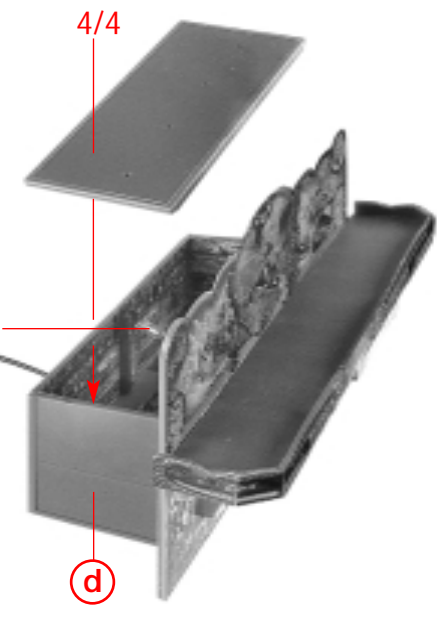

(d)

Deco 15

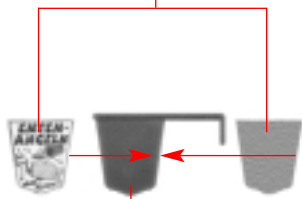

4/14

(f)

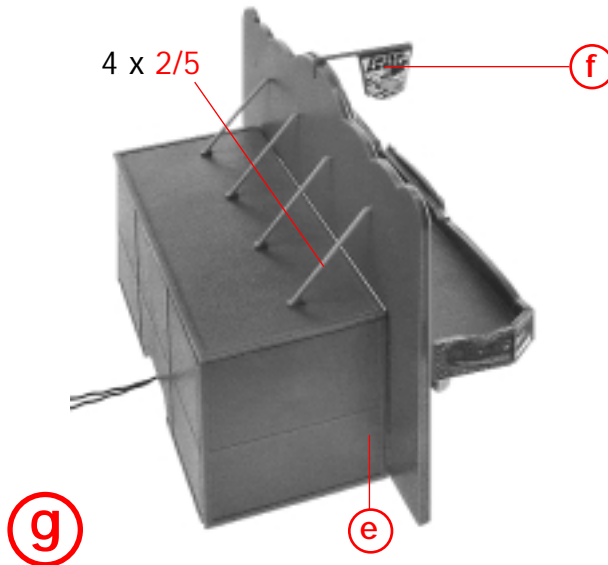

(g)

4 x 2/5

(f)

(e)

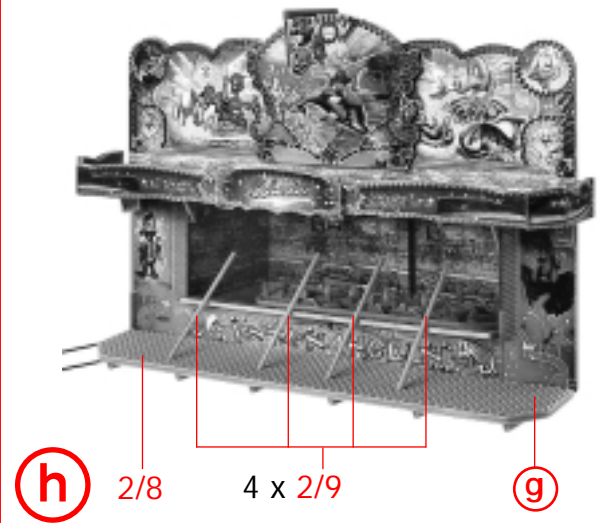

(h)

2/8

4 x 2/9

(g)

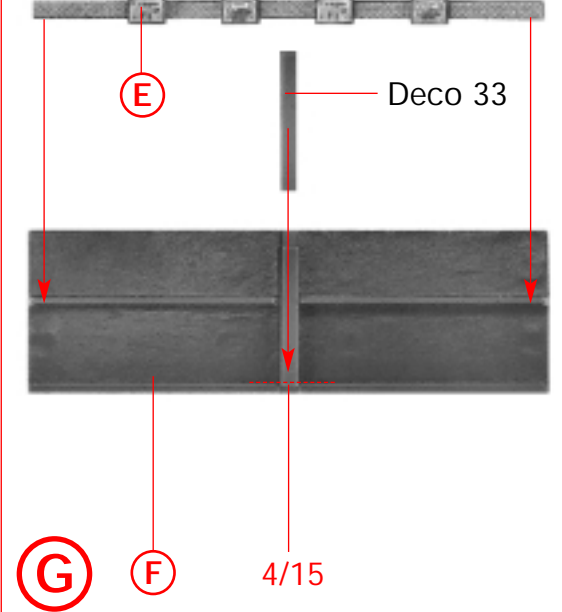
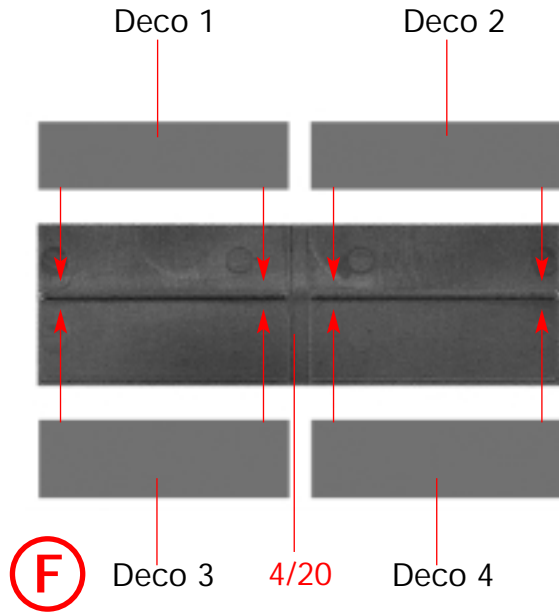
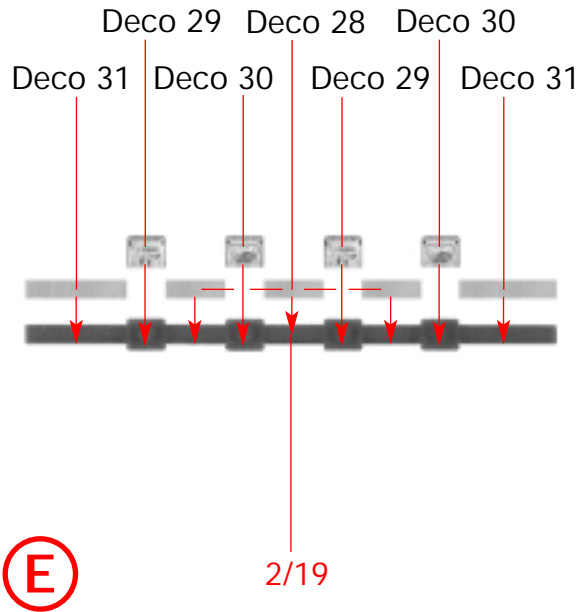
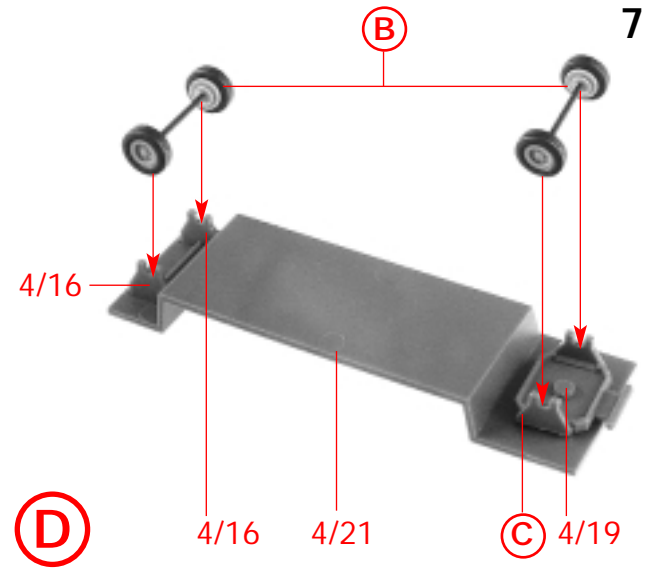
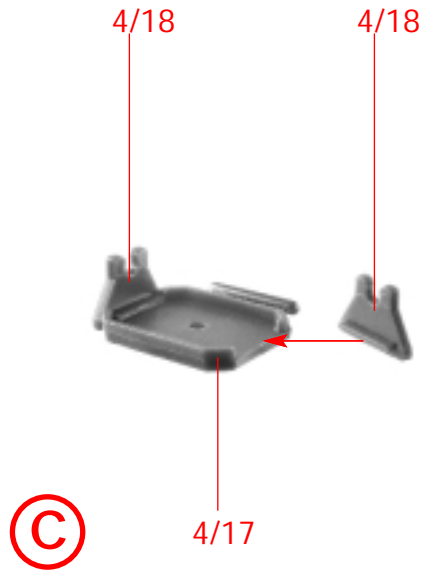
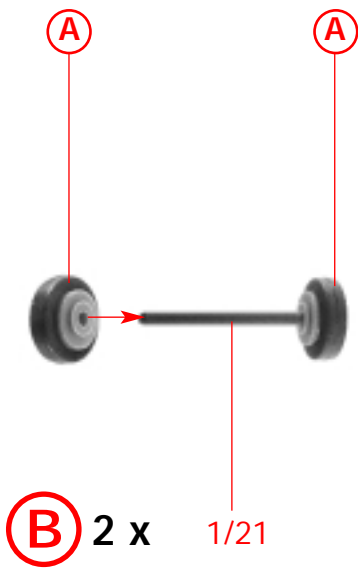
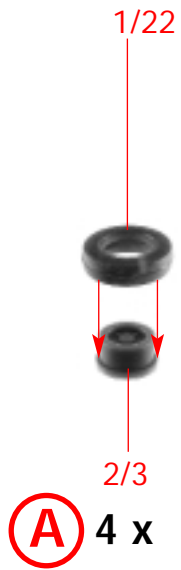

8

Deco 6

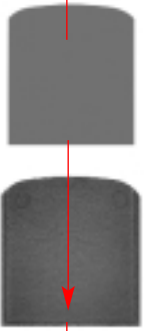

4/23

Deco 5

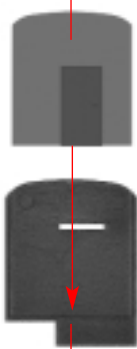

4/22

(H)

(I)

(H)

(I)

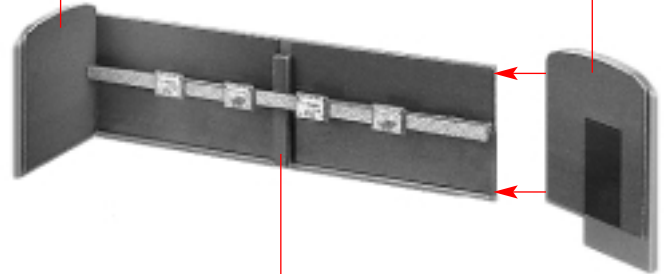

(J)

(G)

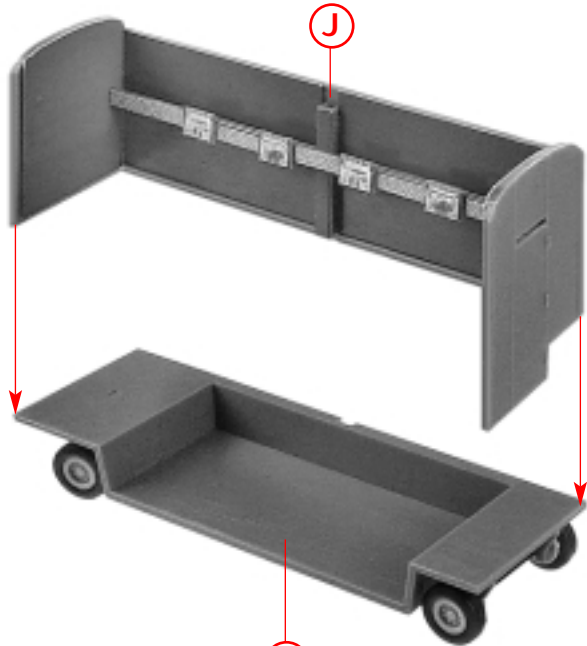

(J)

(K)

(D)

2/18

(K)

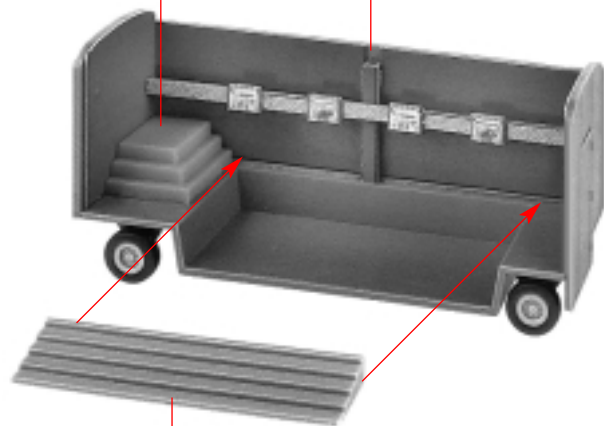

(L)

2/12



30 x 5/8 + 2/20

rot, grün, gelb, blau  
red, green, yellow, blue  
rouge, vert, jaune, bleu  
rood, groen, geel, blauw

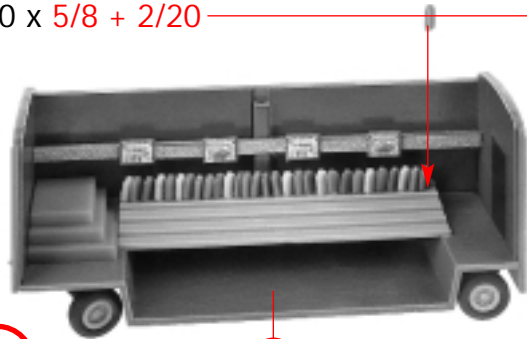

M

L

30 x 5/8 + 2/20

rot, grün, gelb, blau  
red, green, yellow, blue  
rouge, vert, jaune, bleu  
rood, groen, geel, blauw

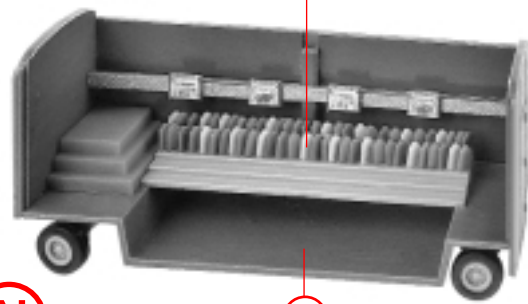

N

M

30 x 5/8 + 2/20

rot, grün, gelb, blau  
red, green, yellow, blue  
rouge, vert, jaune, bleu  
rood, groen, geel, blauw

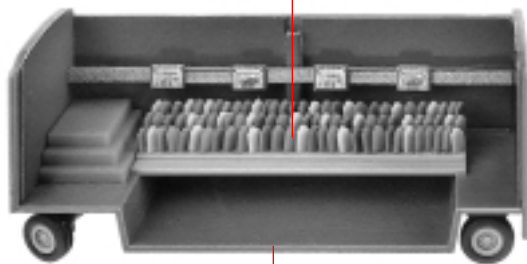

O

N

30 x 5/8 + 2/20

rot, grün, gelb, blau  
red, green, yellow, blue  
rouge, vert, jaune, bleu  
rood, groen, geel, blauw

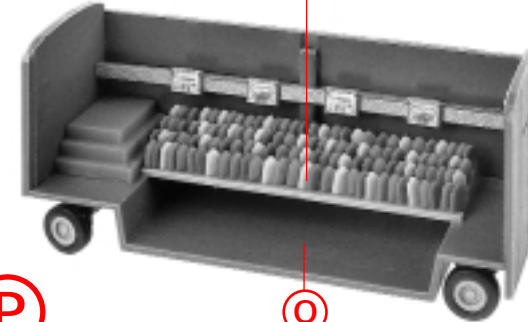

P

O

6 x 3/2 + 6 x 3/1

lila, hellblau, orange  
purple, bright blue, orange  
lilas, bleu clair, orange  
lila, lichtblauw, oranje

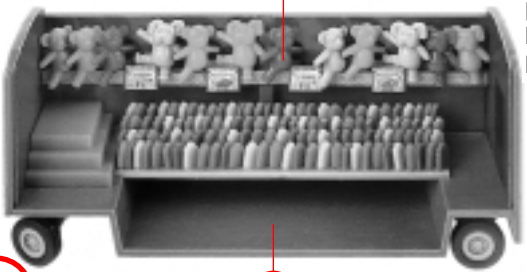

Q

P

3 x 3/2 + 3 x 3/1 + 12 x 3/3 + 12 x 3/4

lila, hellblau, orange  
purple, bright blue, orange  
lilas, bleu clair, orange  
lila, lichtblauw, oranje

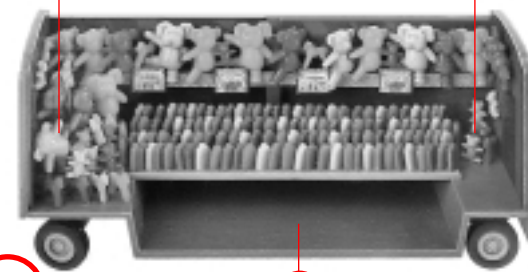

R

Q

10

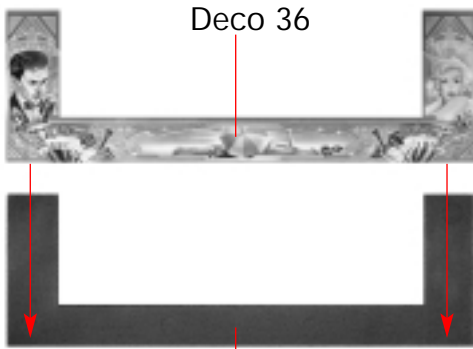

Deco 36

4/26

(S)

(T)

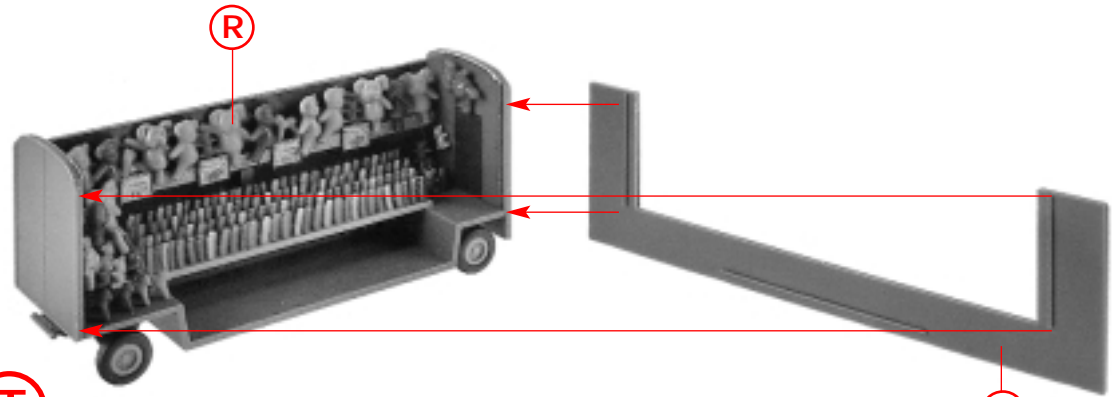

(R)

(S)

4/25

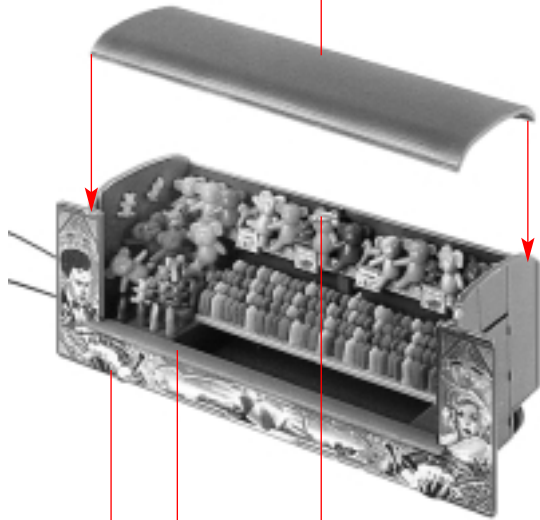

Art.-Nr. 180671 liegt nicht bei  
not included  
non jointe  
niet bijgevoegd

(U)

(T)

2/17

Deco 44 43 42 41 40 39 38 37

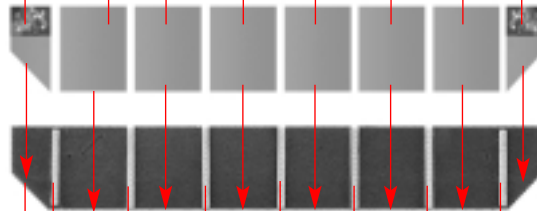

4/27

5 x 5/3

5/2 — gelb, yellow, jaune, geel — 5/2

(V)

Deco durchstechen  
Pirece deco through  
Piquez le deco  
Deco doorstéken

Deco 35

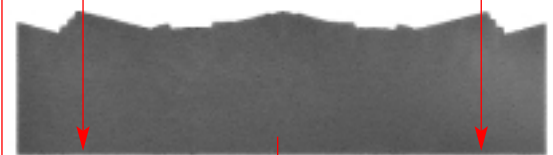
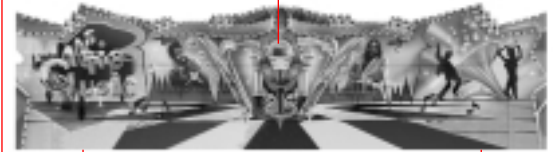

(W)

4/32

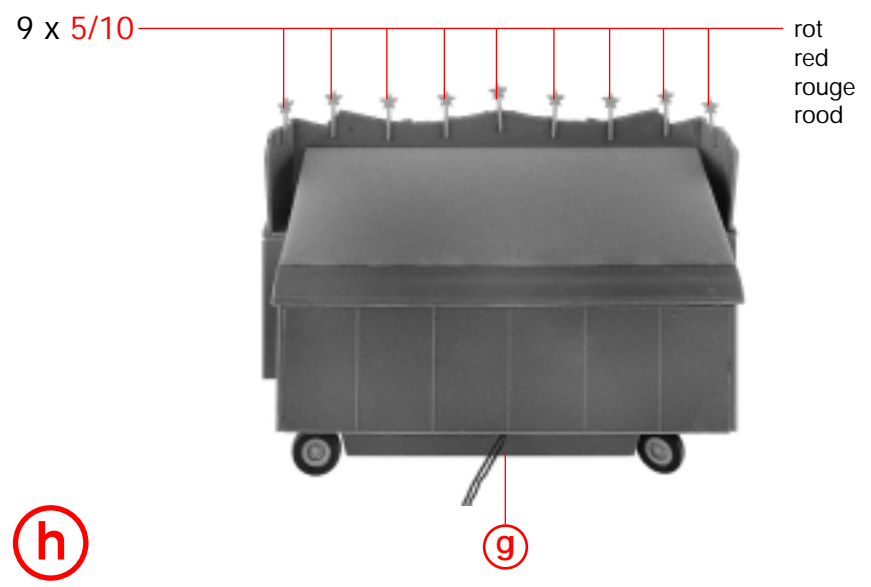
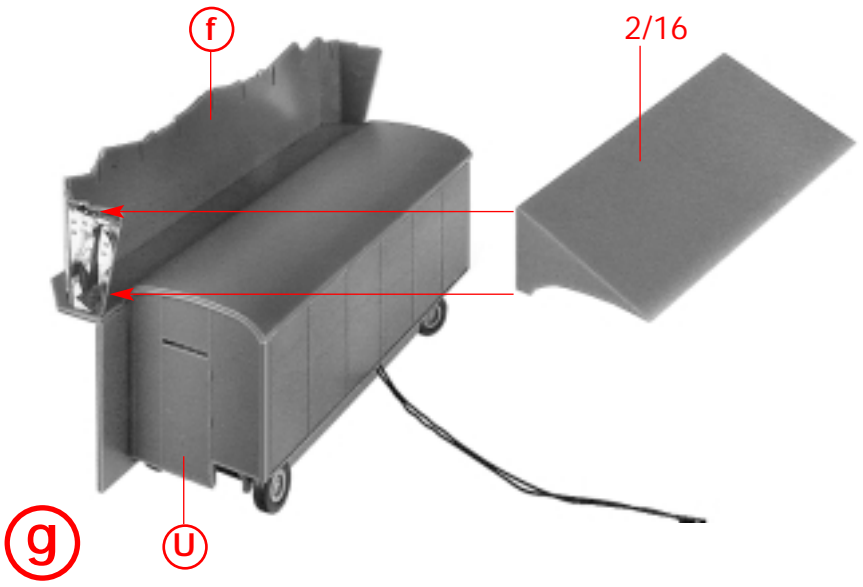
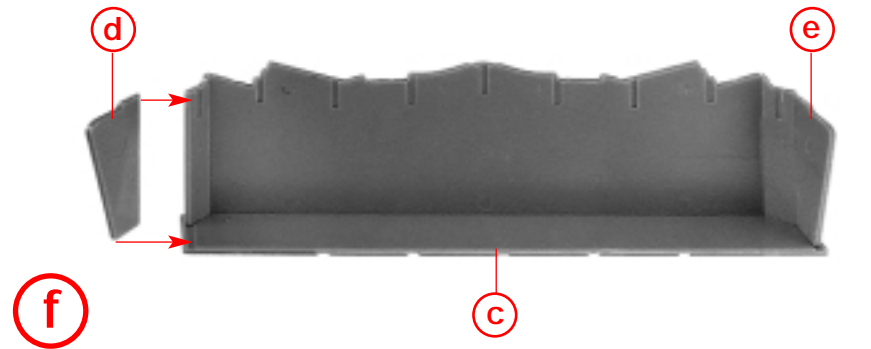
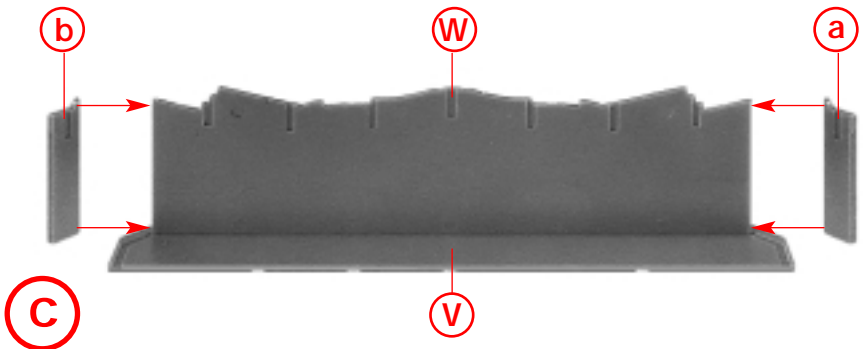
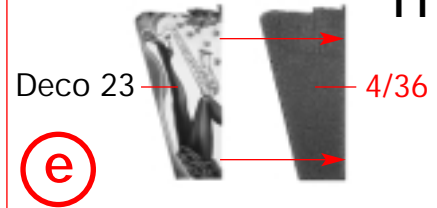
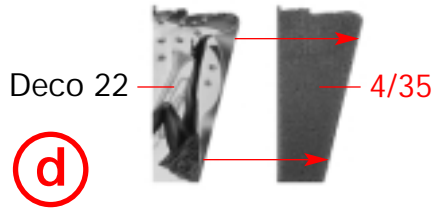
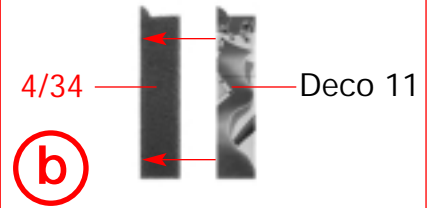
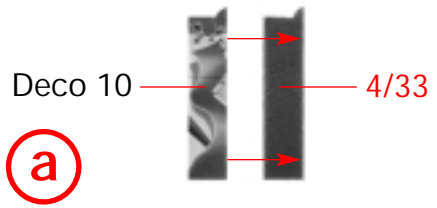

12

2/14

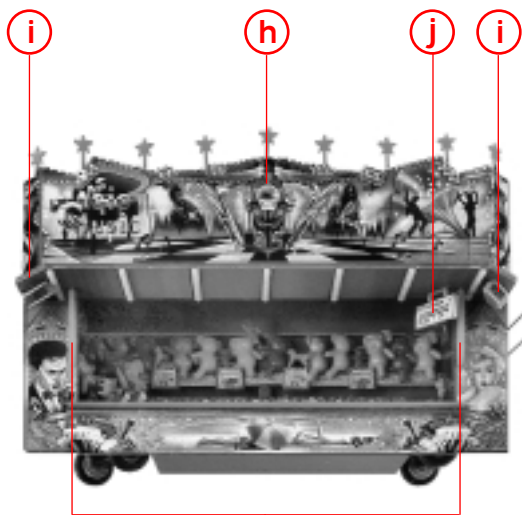

2 x

**i**

Deco 32

**l**

Deco 17

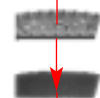

4/30

**n**

Deco 20



4/28

2/13



**j**

Deco 45

**k**

5/9 rot, red, rouge, rood

**m**

Deco 19

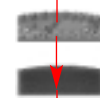

4/29

**o**

Deco 18



4/29

**p**

Deco 16



4/31

**n** **m** **l** 4/24

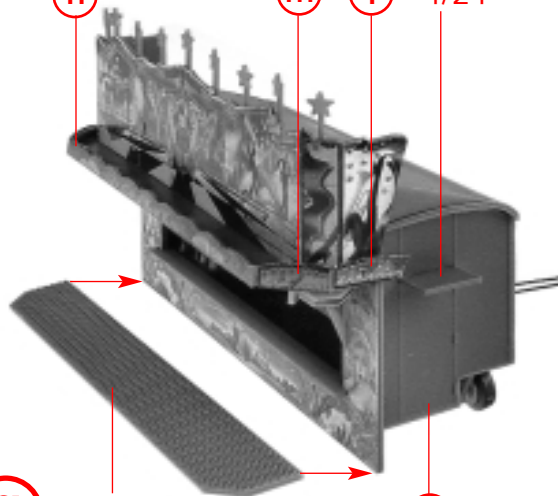

**q**

2/15

**k**

**p** **o**

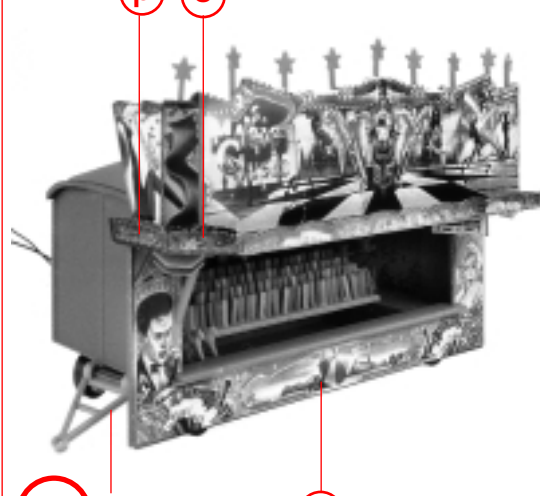

**r**

2/11

**q**

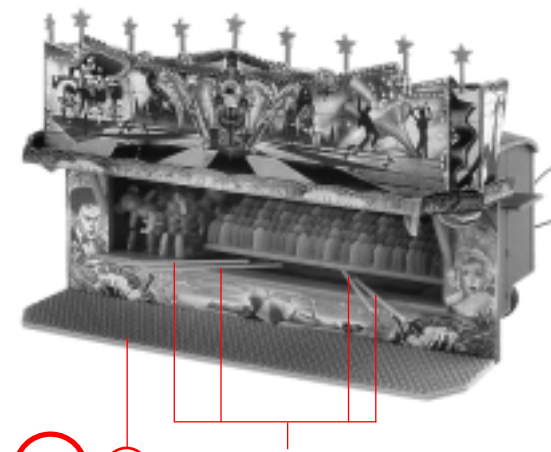

**s**

**r**

4 x 2/9