

- D**
- Vor Beginn des Bastelns sollten Sie sich mit den Spritzlingen und der Anleitung vertraut machen.
  - Sollte es einmal vorkommen, daß ein Teil im Bausatz fehlt, kreuzen Sie bitte das fehlende Teil in der Anleitung an und schicken Sie diese bitte an Fa. Gebr. FALLER GmbH, Abt. Kundendienst, Postfach 1120, 78148 Gütenbach. Sie erhalten dann umgehend Ersatz.
  - **In diesem Bausatz sind einige Kunststoffteile übrig.**

- GB**
- Before commencing with the assembly please familiarize yourself with the parts and read the instructions carefully.
  - In case of missing part(s) please indicate these on the instructions leaflet with a circle and return the leaflet to Gebr. FALLER GmbH, Postfach 1120, 78148 Gütenbach, Germany. You will receive the replacement by return.
  - **Some of the parts in this box are not needed to construct the model.**

- F**
- Avant de commencer le montage de votre maquette bien lire la notice et repérer les grappes.
  - Si une pièce manquait dans une boîte, cochez la pièce correspondante sur la notice et renvoyez la nous à Gebr. FALLER GmbH, Postfach 1120, D-78148 Gütenbach (R.F.A.). Nous vous ferons parvenir la pièce par retour.
  - **Dans cette boîte se trouvent quelques pièces qui ne seront pas utilisées pour le montage.**

- NL**
- Vóór het bouwen zou men de gietstukken en de handleiding moeten bestuderen.
  - Indien onverhoopt een onderdeel aan het bouwpakket ontbreekt, gelieve men het ontbrekende deel in de handleiding aan te kruisen en deze te zenden aan Gebr. FALLER GmbH, Postfach 1120, D-78148 Gütenbach. U ontvangt dan omgaand en gratis het ontbrekende onderdeel.
  - **Van dit bouwpakket worden enkele kunststof delen niet gebruikt.**

**492  
EXPERT**

Flüssigkleber in Plastikflasche mit Spezialkanüle für feinste Klebstoffdosierung.

Liquid cement in plastic bottle with canule for very fine dosages.

Colle liquide en bouteille plastique avec bec verseur pour un dosage précis.

Vloeibare lijm in plastic-flacon met doseerbuisje om nauwkeurig te lijmen.



**688**

**Spezial-Seitenschneider**  
zum gratfreien Abtrennen von feinsten Spritzteilen. Spitze 48° abgewinkelt. Nur für Polystyrol geeignet.

**Special side cutter**  
for cutting off ultra-fine moulded parts without burrs. Tip angle 48°. Only suitable for polystyrene.

**Pince coupante spéciale**  
pour couper sans bavure les pièces miniatures moulées par injection. Pointe coudée à 48°. Uniquement appropriée pour le polystyrène.

**Speciale zijknijptang**  
voor het braamloos afknippen van de fijnste gietstukdelen. Hoek snijvlakken 48°. Alleen geschikt voor polystyrol.



<b>Inhalt</b>	Spritzlinge	<input type="checkbox"/> 1	1 x	<input type="checkbox"/> 4	1 x	<input type="checkbox"/> 7	1 x	<input type="checkbox"/> 10	1 x
<b>Contents</b>	Sprues	<input type="checkbox"/> 2	1 x	<input type="checkbox"/> 5	1 x	<input type="checkbox"/> 8	1 x	<input type="checkbox"/> 11	1 x
<b>Contenu</b>	Moulages	<input type="checkbox"/> 3	1 x	<input type="checkbox"/> 6	1 x	<input type="checkbox"/> 9	1 x	<input type="checkbox"/> 14	1 x
<b>Inhoud</b>	Gietstukken	<input type="checkbox"/> 3	1 x	<input type="checkbox"/> 6	1 x	<input type="checkbox"/> 9	1 x	<input type="checkbox"/> 14	1 x

## 2 Fensterfolie

Schnittmusterfolie für Fenster von Trägermaterial abziehen und auf die Fensterfolie mit gleicher Größe blasenfrei aufbringen **(ohne Klebstoff!)**.

Die benötigten Fenster werden ausgeschnitten und **ohne Schnittmusterfolie** auf die Rückseite der Fensterrahmen geklebt (Position laut Anleitung).

### Window foil

Pull off pattern sheet for window from carrier and apply it, bubble-free, to the window foil of the same size **(without using adhesive)**.

Cut out the required windows and glue them to the rear side of the window frame **without pattern sheet** (position as specified in instructions).

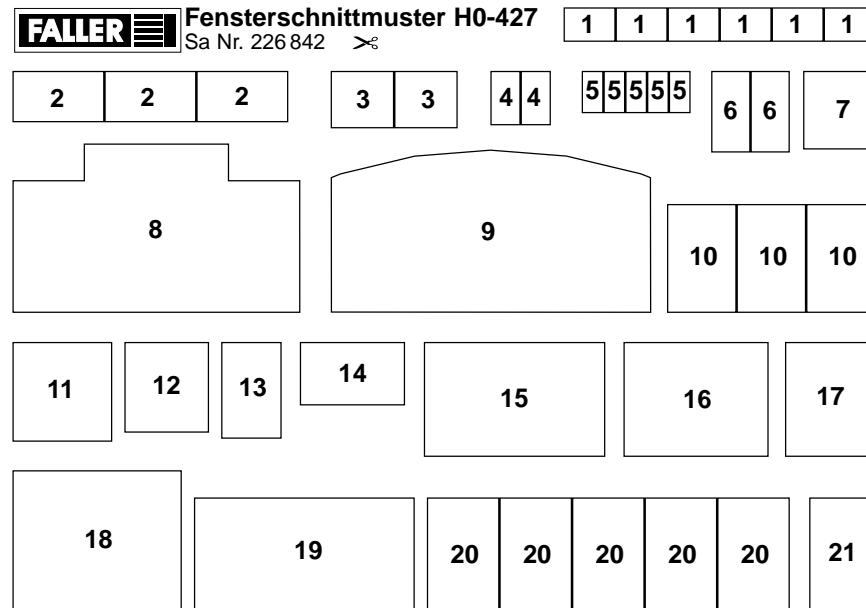

## Feuille fenêtre

Retirer la feuille modèle du support et l'appliquer sur la feuille fenêtre de même grandeur sans qu'il se forme de bulles **(sans colle)**.

Découper le nombre de fenêtres nécessaires et les coller **sans la feuille** modèle sur l'arrière des dormants (position, voir mode d'emploi).

### Raam folie

De folie met knip- resp. snijpatronen voor de ramen van het schutblad aftrekken en op de raam folie van dezelfde grootte aanbrengen en luchtblaasjes wegdrücken **(niet lijmen!)**.

De benodigde ramen worden uitgeknipt resp. -gesneden en **zonder de patroonlijnen** op de achterkant van de ramen gelijmd (positie volgens handleiding).

Spritzlinge	1
Sprues	2
Moulages	4
Gietstukken	4

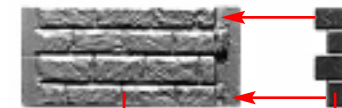

4/21

2/45

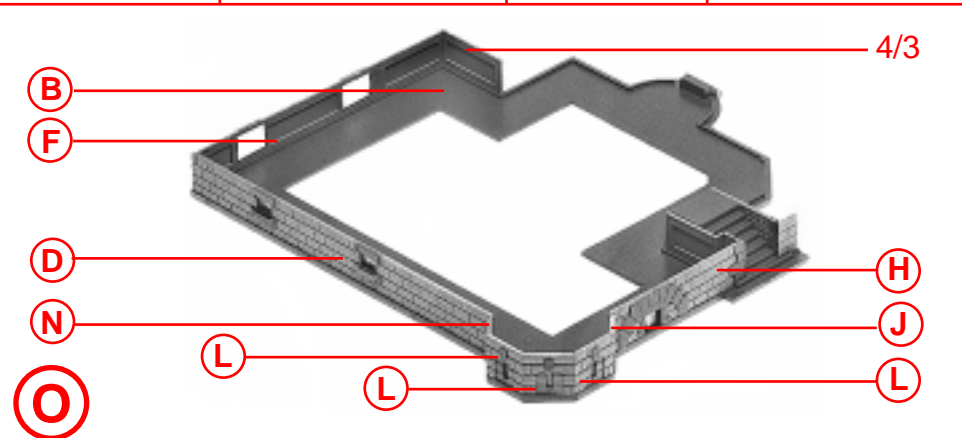
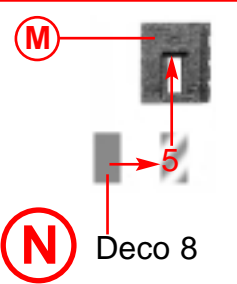
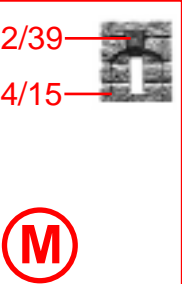
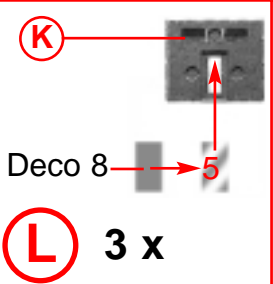
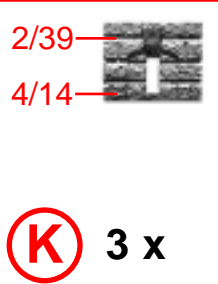
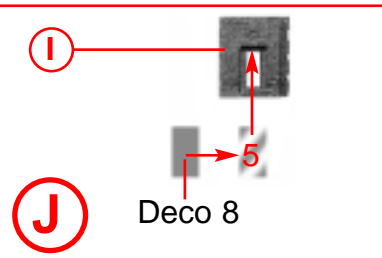
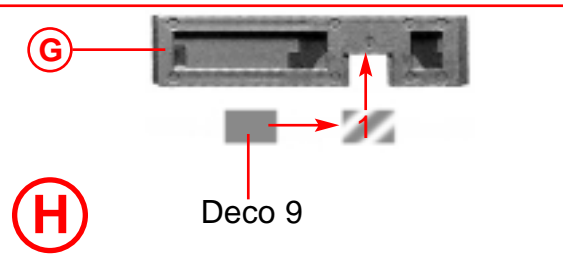
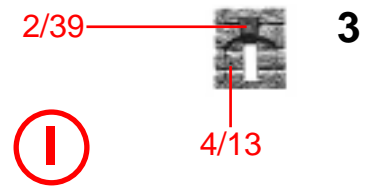
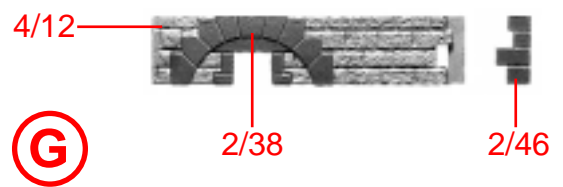
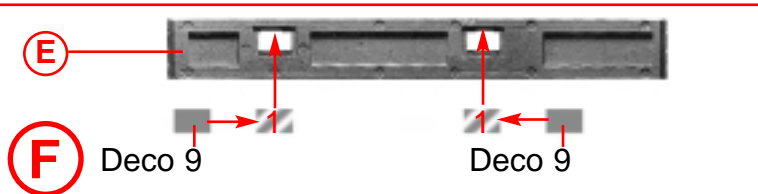
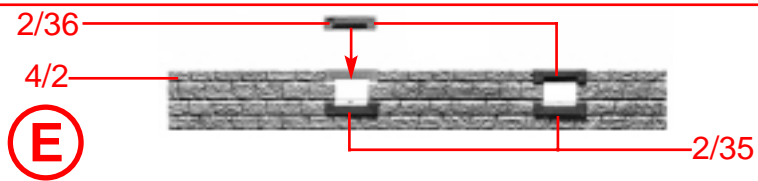
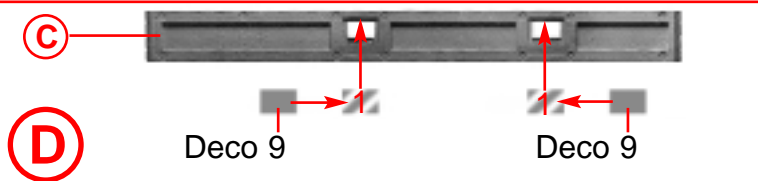
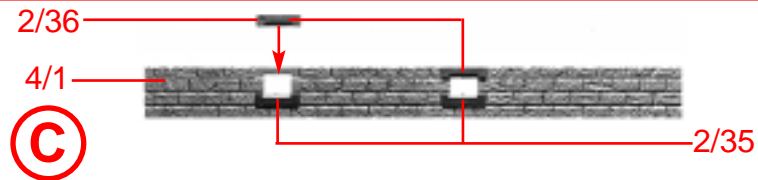
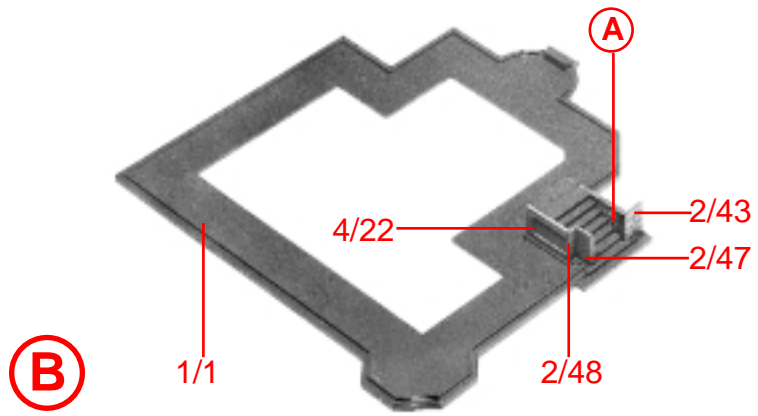

4

Spritzlinge	1	5	11
Sprues	2	7	
Moulagés	4	8	
Gietstukken	4	8	

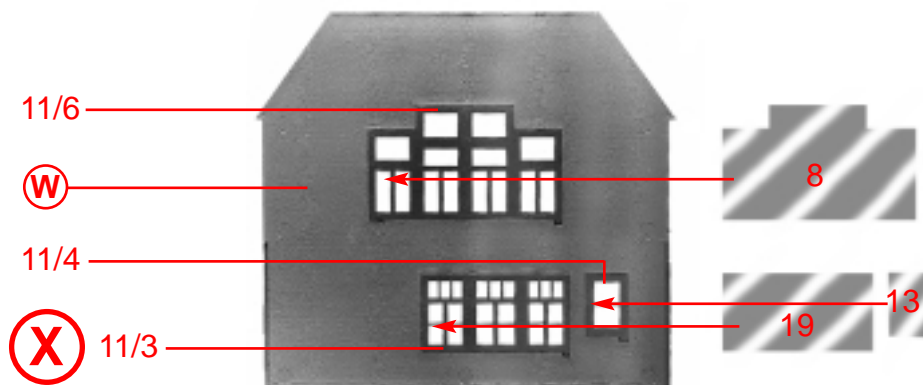
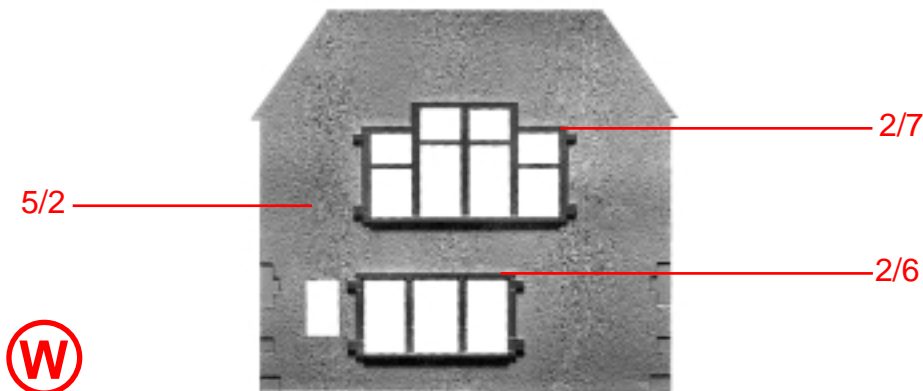
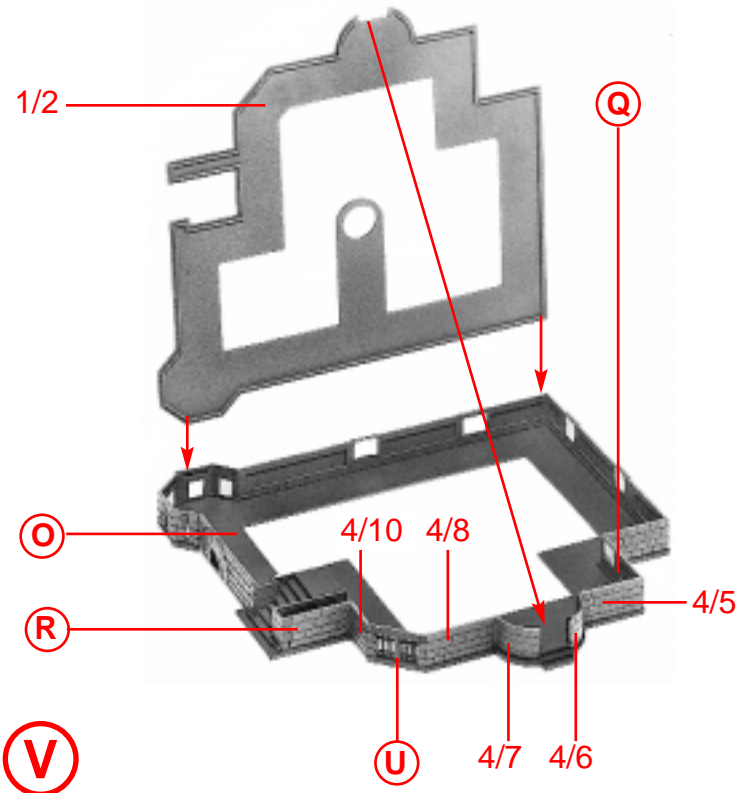
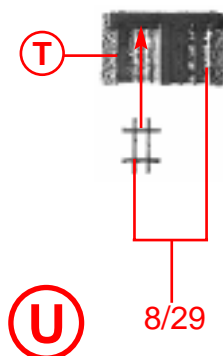
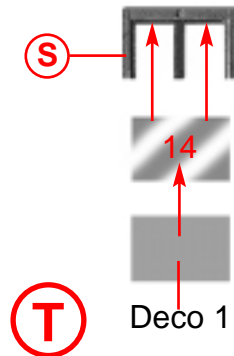
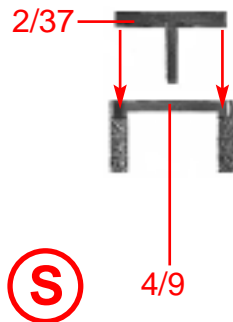
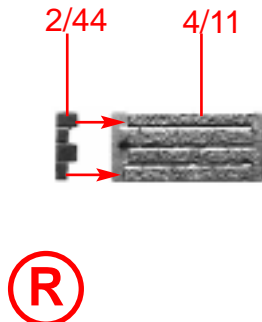
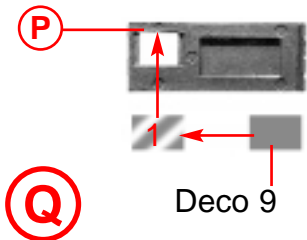
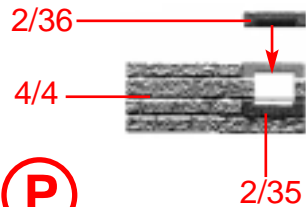

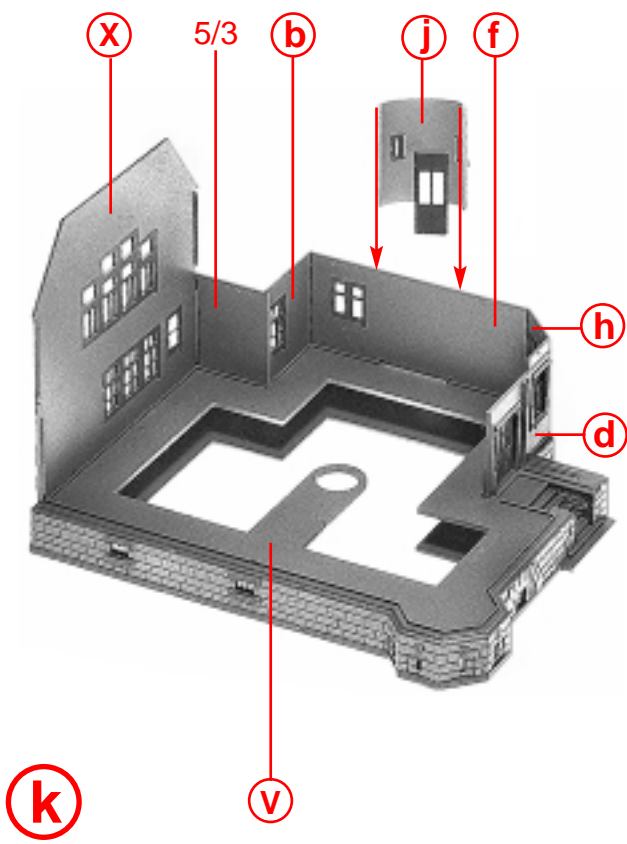
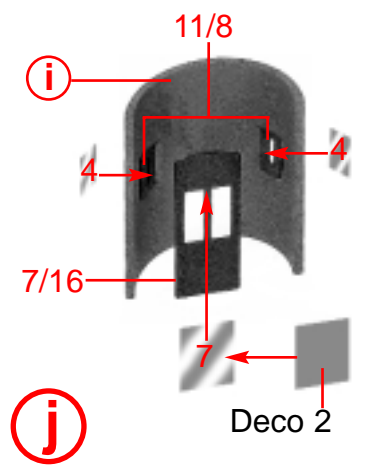
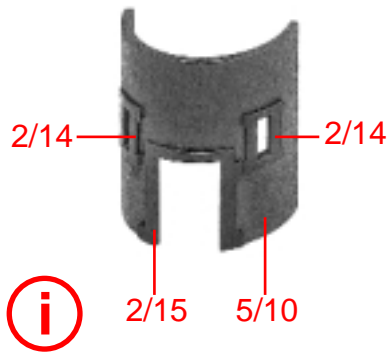
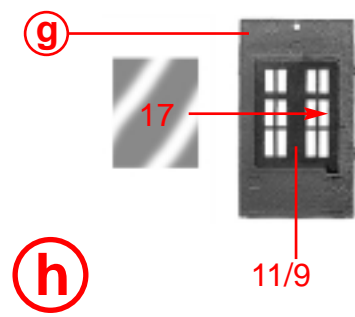
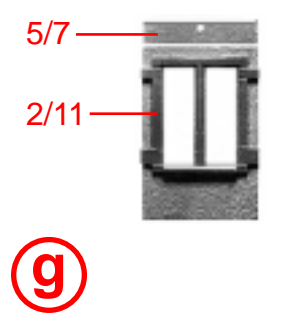
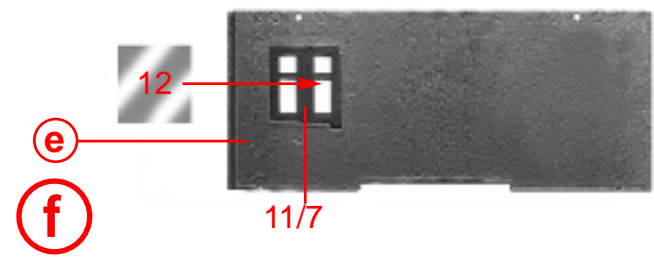
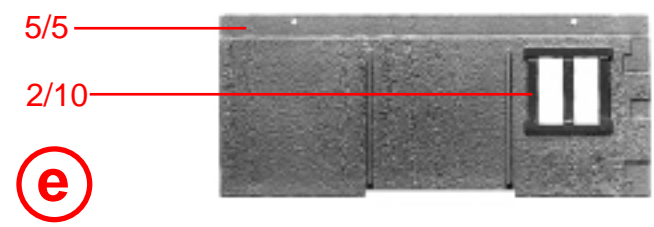
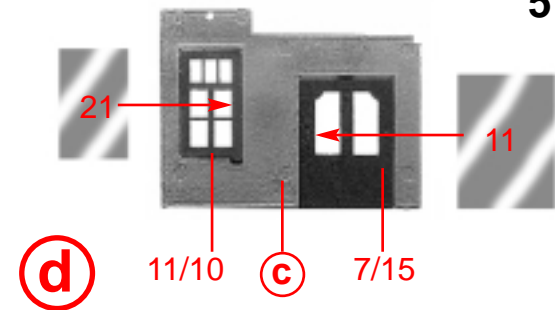
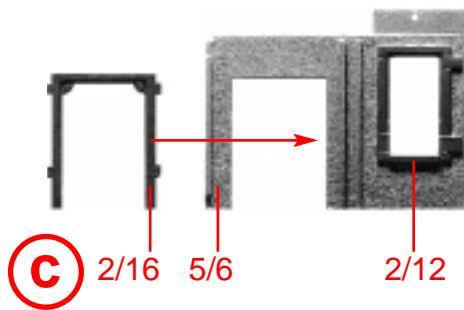
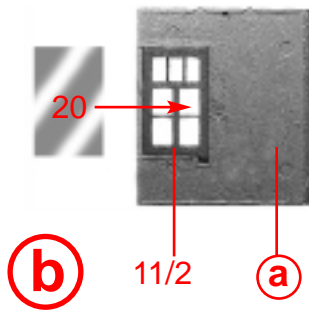
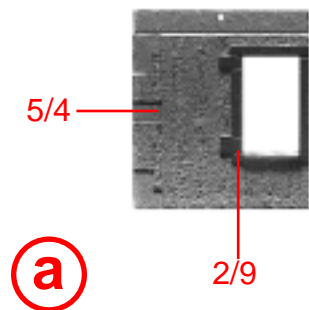

6

Spritzlinge	2	8
Sprues	3	11
Moulages	5	

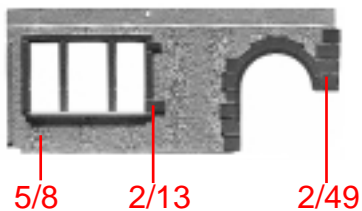

l

3/2

l

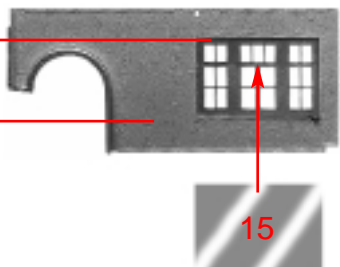

m

5/1

n

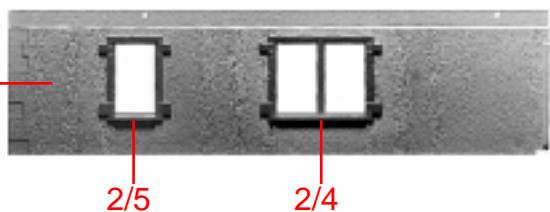

o

11/1

n

16

20

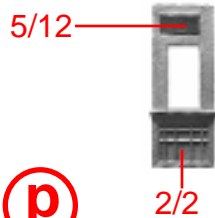
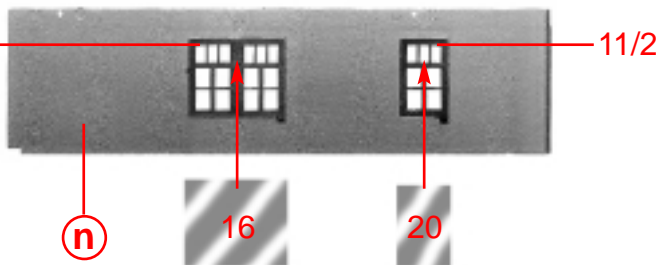

p

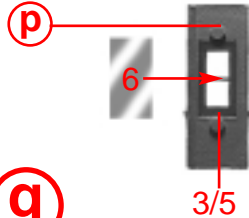

q

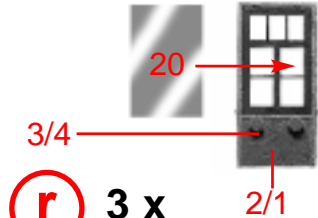

r 3 x

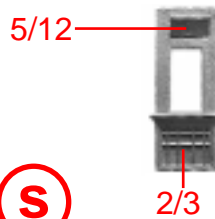

s

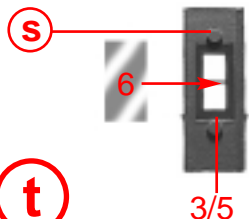

t

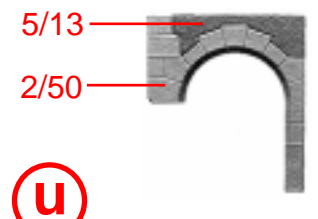

u

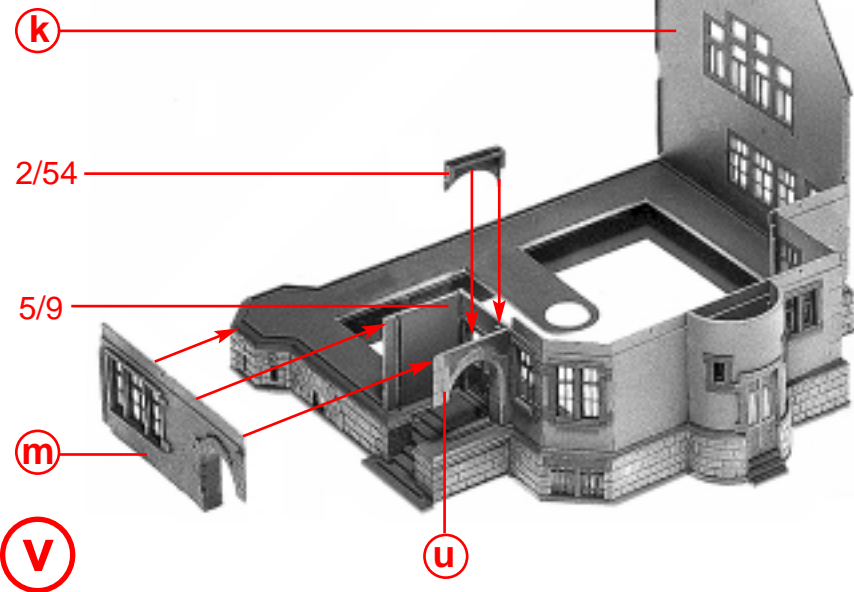

k

2/54

5/9

m

v

u

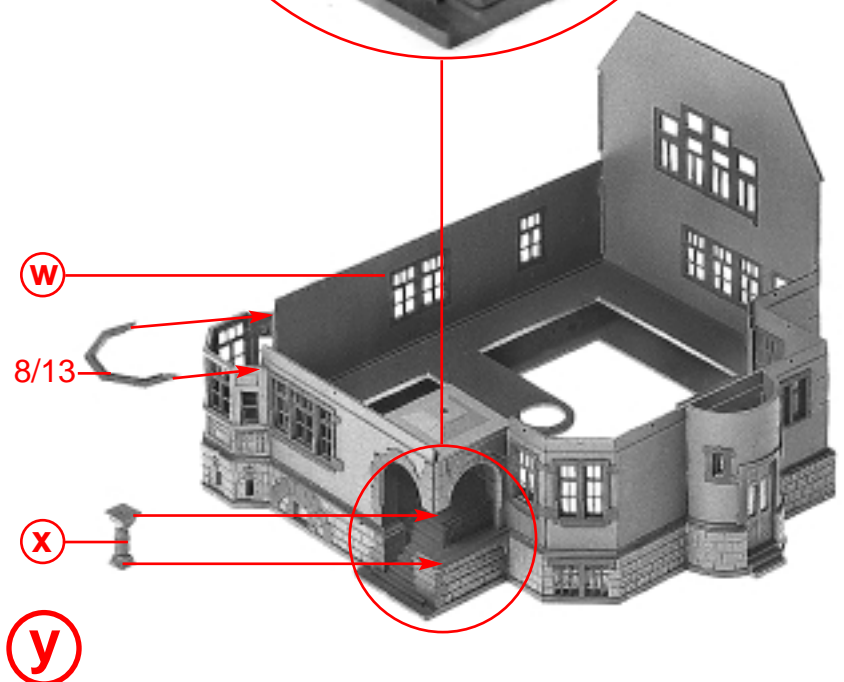
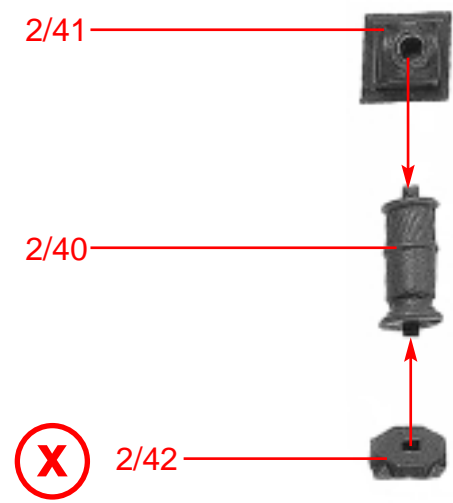
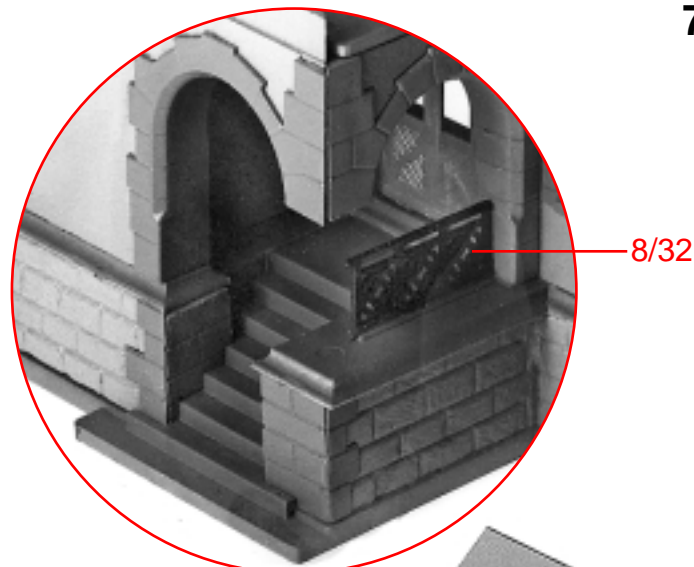
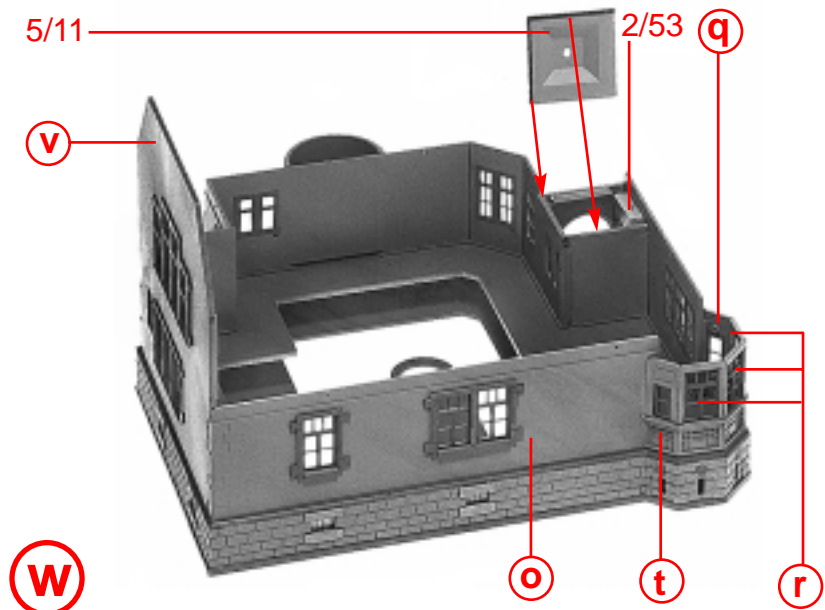

8

Spritzlinge	3
Sprues	6
Moulages	6
Gietstukken	7

Papiermaske zur Lichtabdeckung  
Black-out masking paper  
Masque en papier noir **M 1**  
Masker voor de lichtafscherming

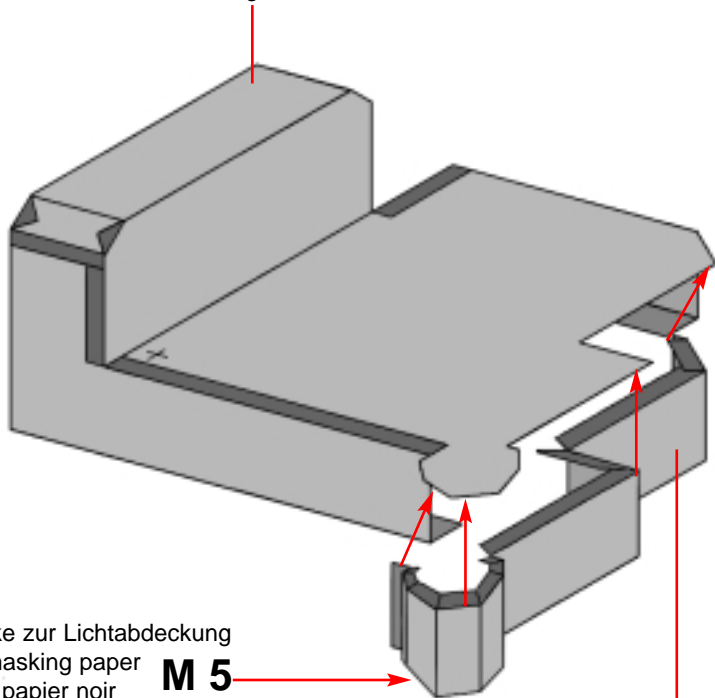

Papiermaske zur Lichtabdeckung  
Black-out masking paper  
Masque en papier noir **M 5**  
Masker voor de lichtafscherming



Papiermaske zur Lichtabdeckung  
Black-out masking paper  
Masque en papier noir **M 4**  
Masker voor de lichtafscherming

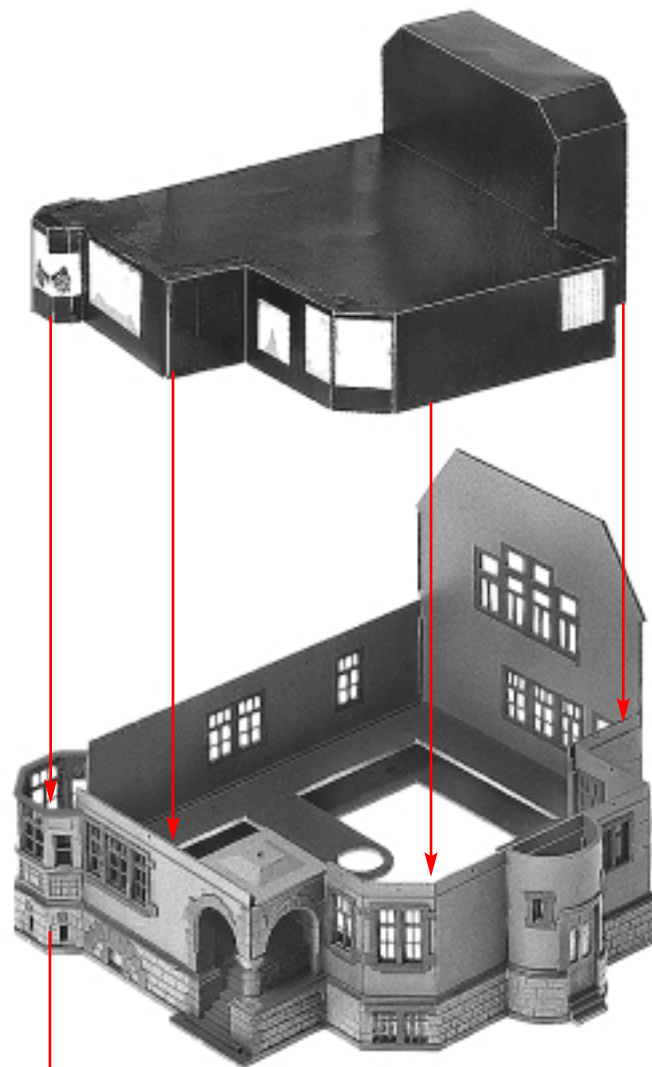

**A**

**y**



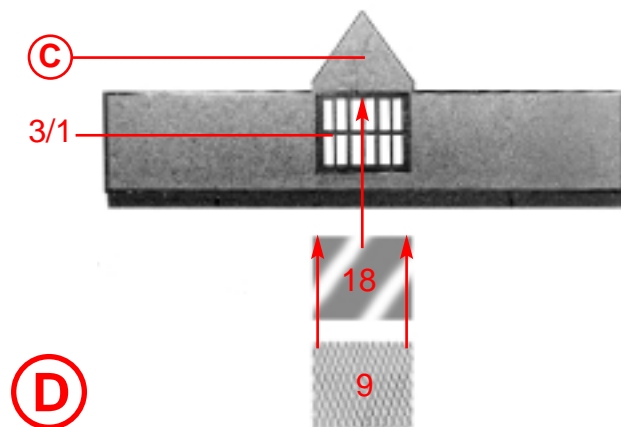
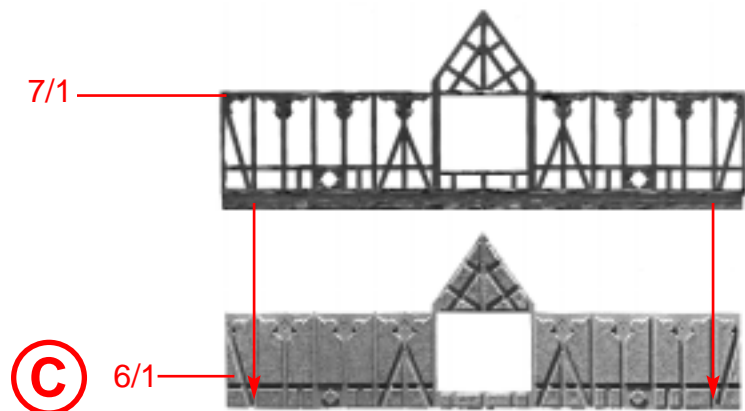
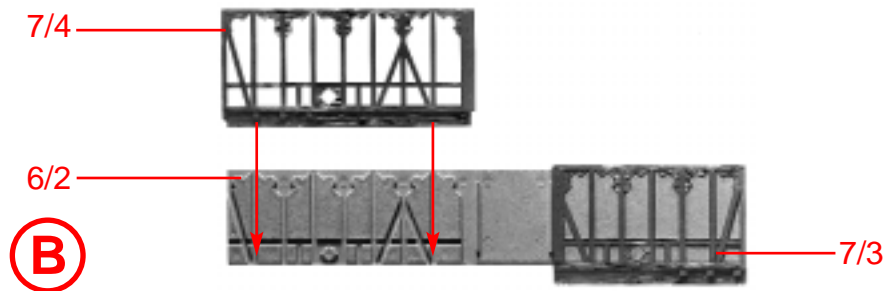

Selbstklebefolie 9 von Trägermaterial abziehen, auf die Fensterfolie aufreiben und ausschneiden.  
Pull off self-adhesive decorative sheet 9 from carrier, apply it bubble-free to the window foil and cut it out.  
Retire déco autocollant 9 du matériau support, l'applique sans formation de bulles et le découpe.  
Zelfplakkend deco 9 van het schutblad aftrekken, op de raam folie zonder luchtblaasjes aanbrengen en uitknippen.

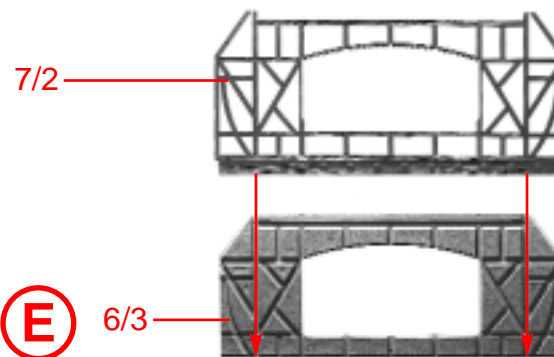

Selbstklebefolie 8 von Trägermaterial abziehen, auf die Fensterfolie aufreiben und ausschneiden.  
Pull off self-adhesive decorative sheet 8 from carrier, apply it bubble-free to the window foil and cut it out.  
Retire déco autocollant 8 du matériau support, l'applique sans formation de bulles et le découpe.  
Zelfplakkend deco 8 van het schutblad aftrekken, op de raam folie zonder luchtblaasjes aanbrengen en uitknippen.

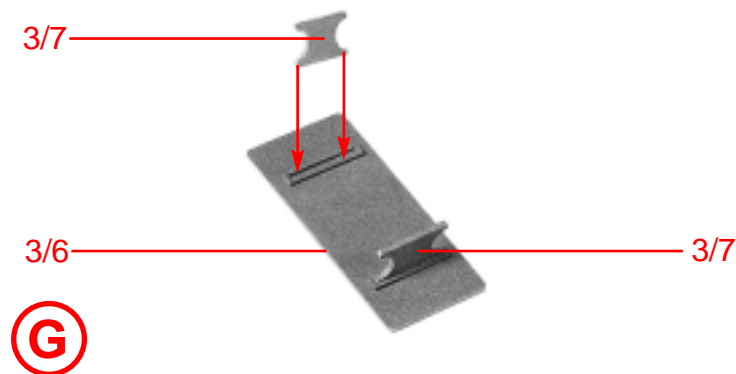
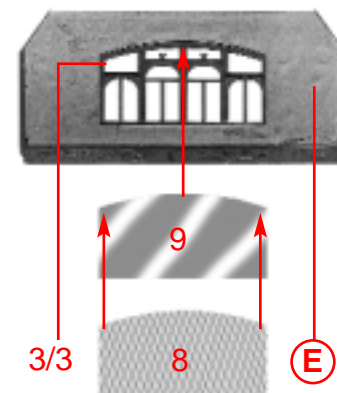

10

Spritzlinge	4	14
Sprues	6	
Moulages	7	
Gietstukken	7	

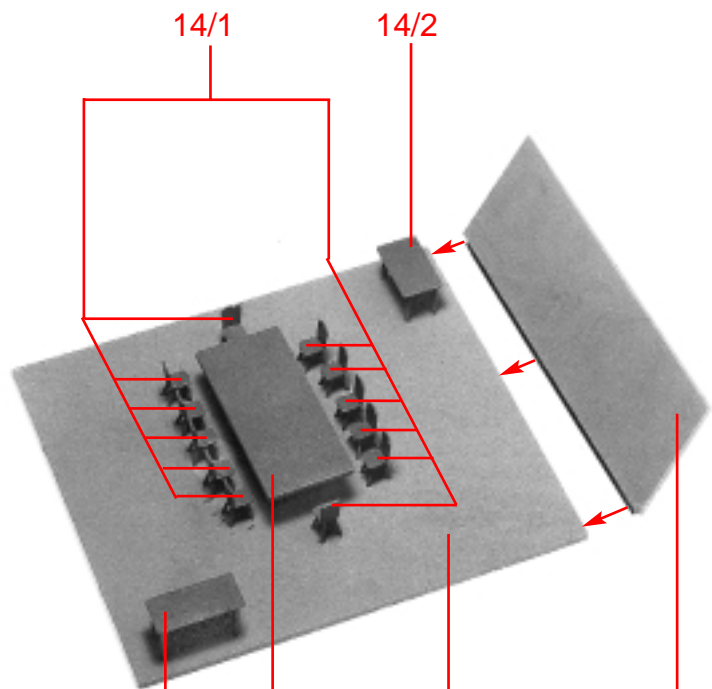

H

14/2

G

4/19

4/20

H

D

F

B

I

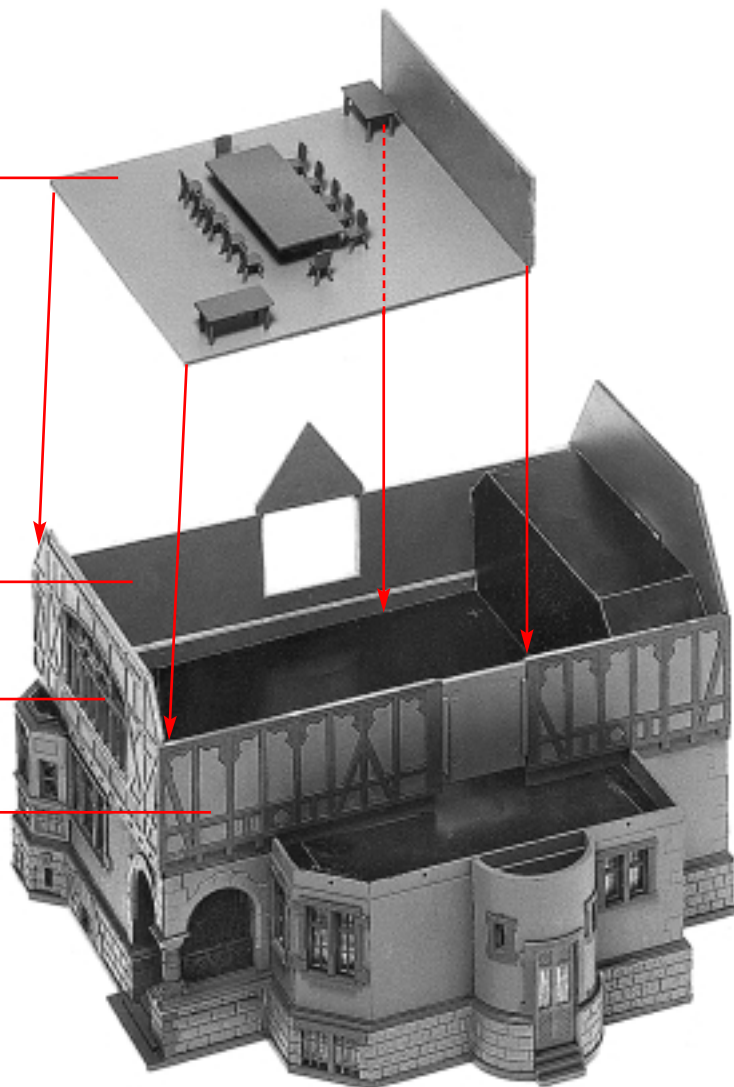

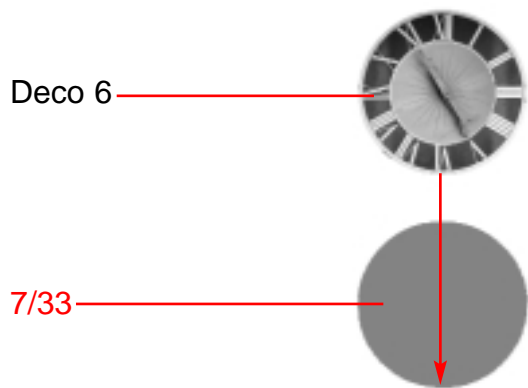

J

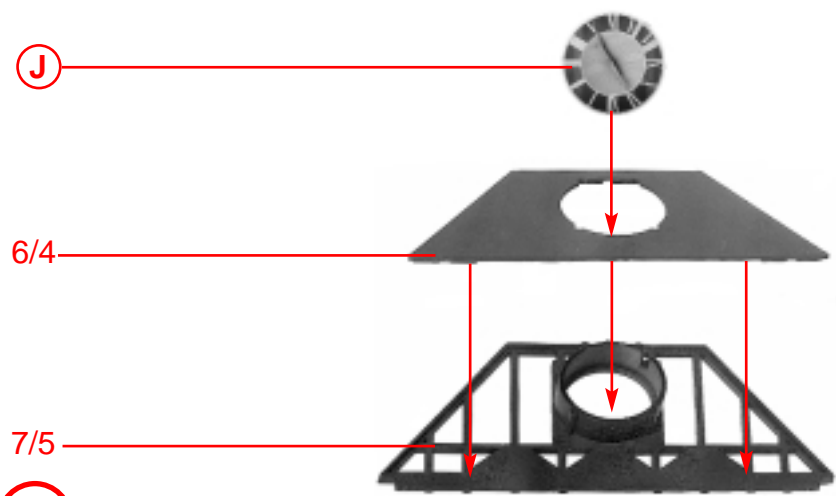

K

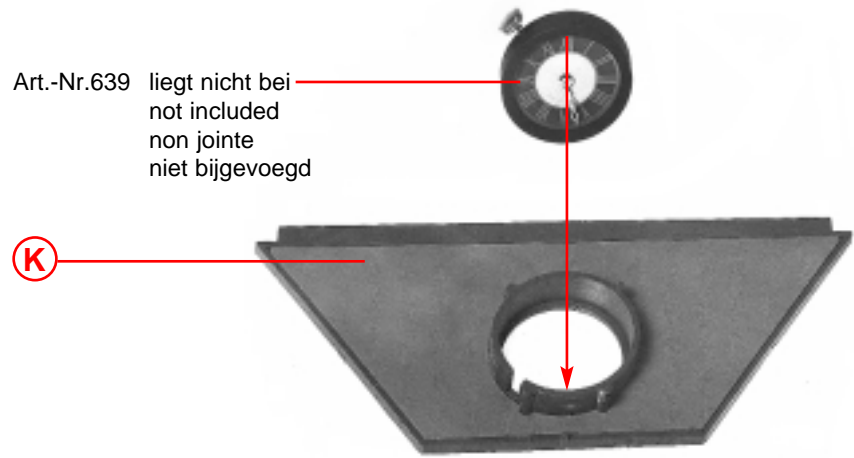

L

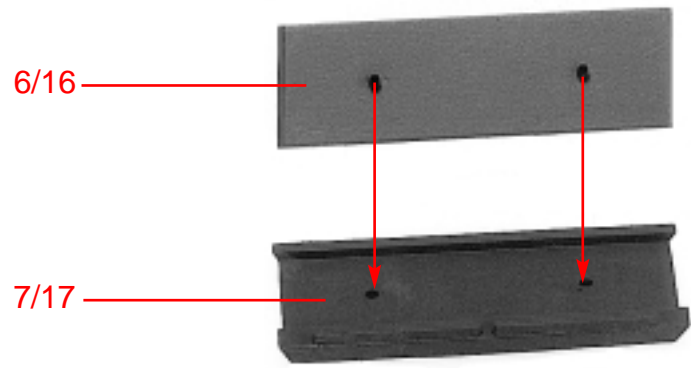

M

12

Spritzlinge	2	8
Sprues	6	
Moulages	7	
Gietstukken		

Papiermaske zur Lichtabdeckung  
 Black-out masking paper  
 Masque en papier noir **M 4**  
 Masker voor de lichtafscherming

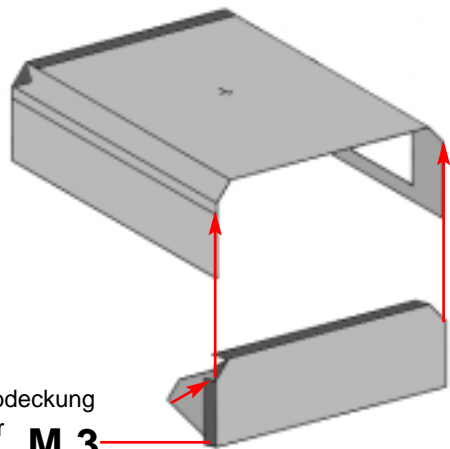
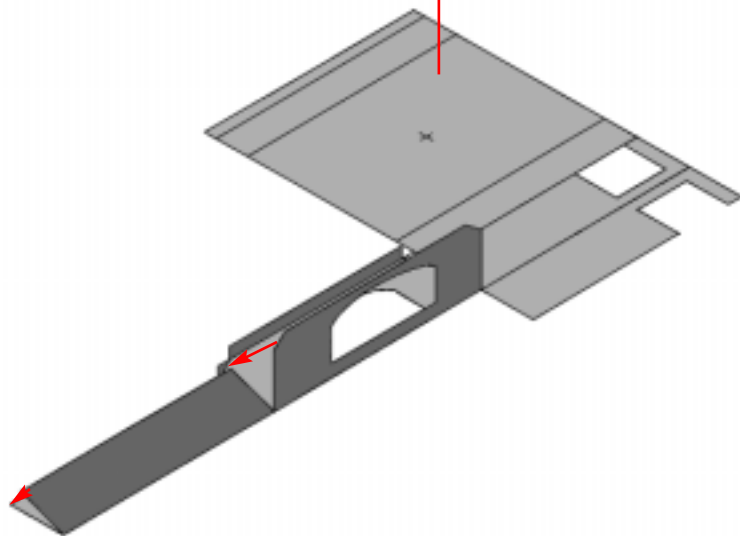

**N**

Papiermaske zur Lichtabdeckung  
 Black-out masking paper  
 Masque en papier noir **M 3**  
 Masker voor de lichtafscherming

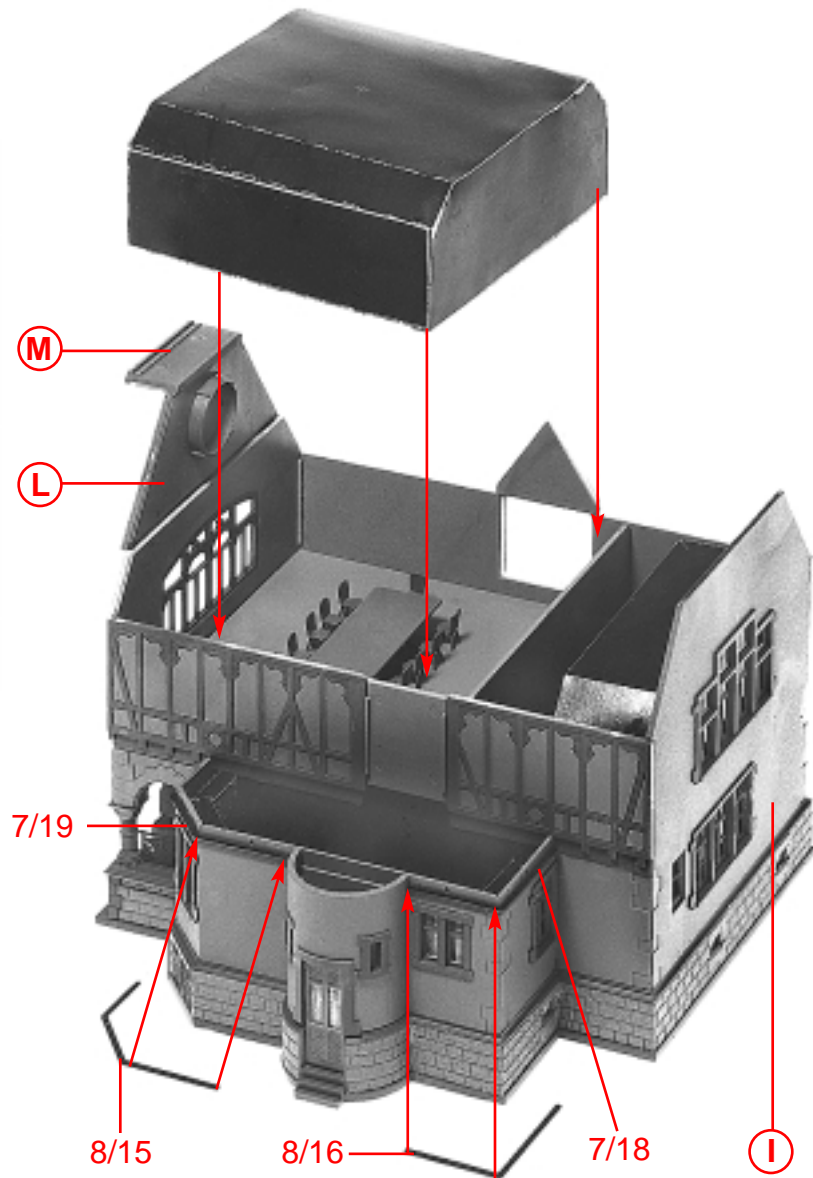

2/52

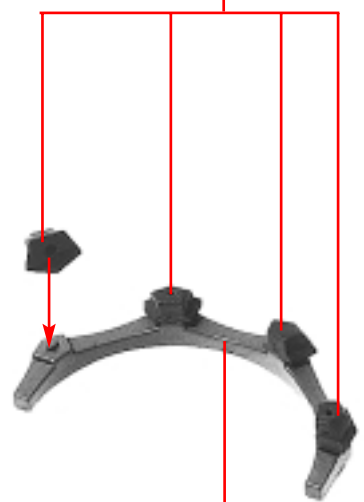

2/51



Papiermaske zur Lichtabdeckung  
Black-out masking paper  
Masque en papier noir  
Masker voor de lichtafscherming

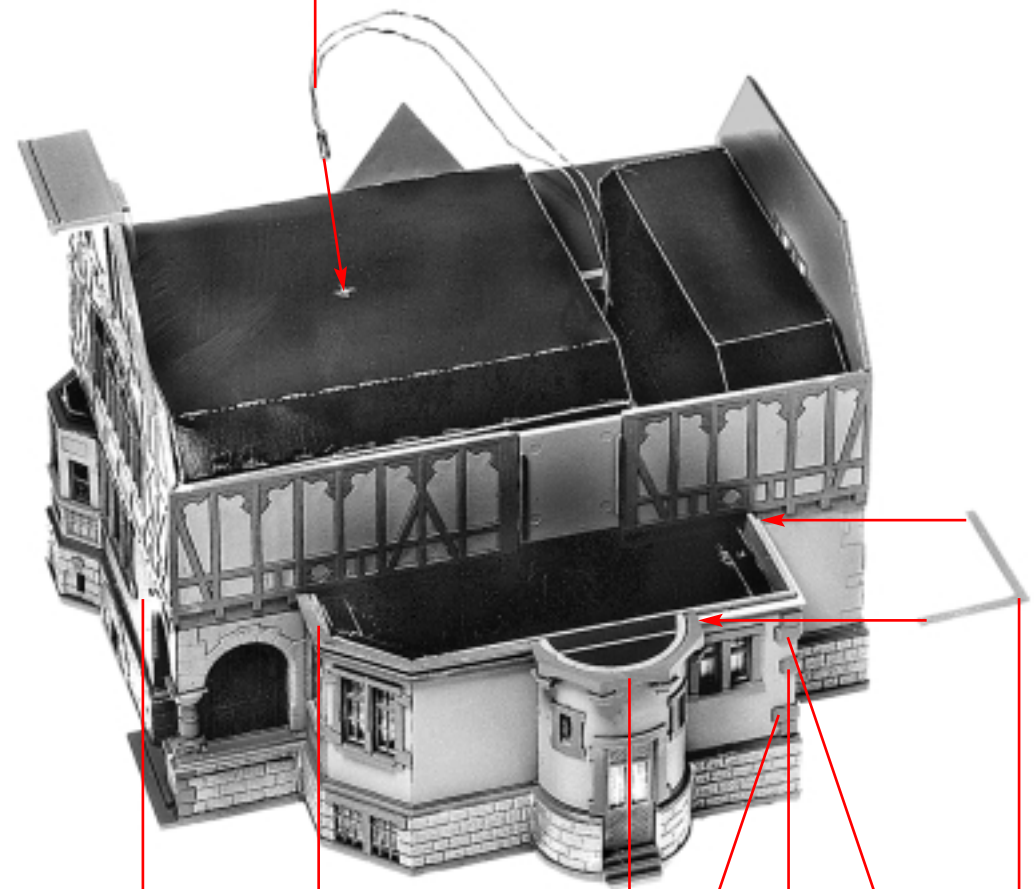

N

6/18



2/34

2/33

2/32

6/17

14

Spritzlinge	3	7	10
Sprues	4	8	
Moulages	6	9	
Gietstukken			

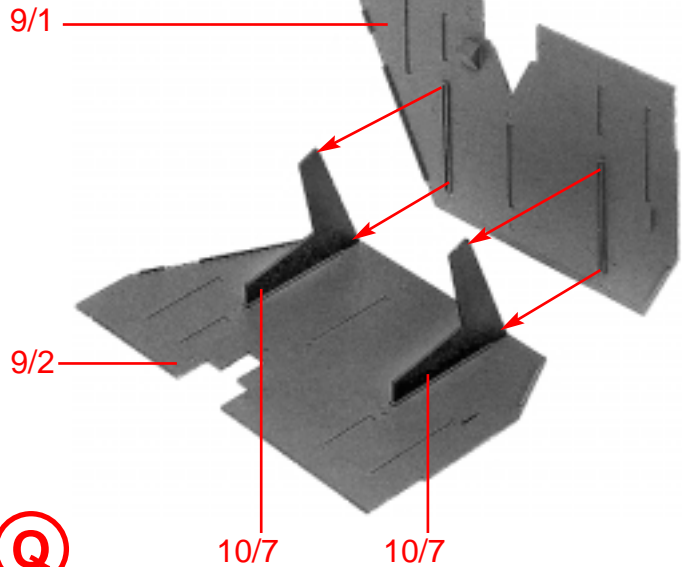

Q

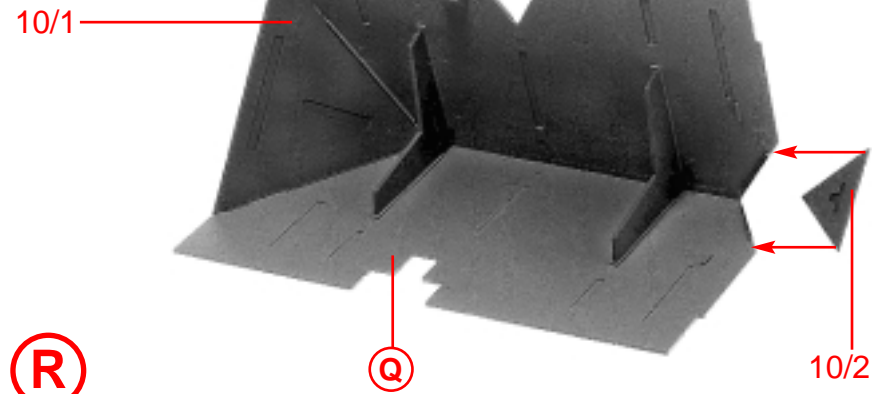

R

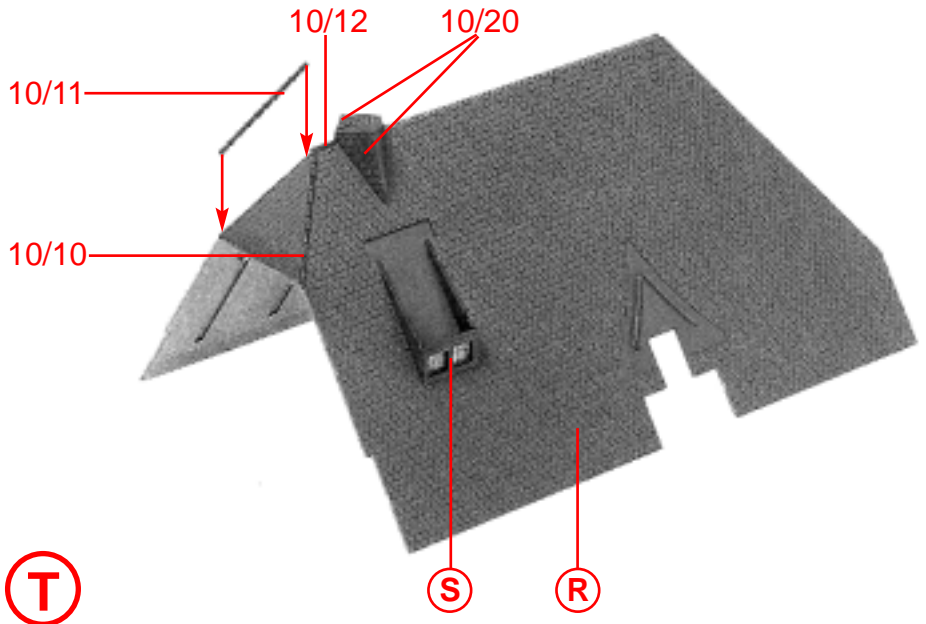

T

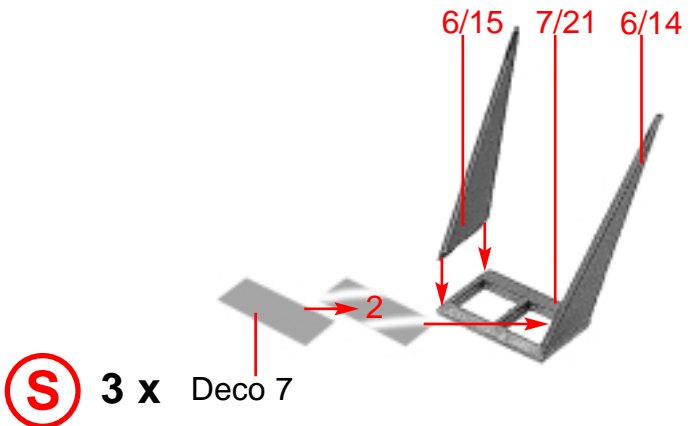

S

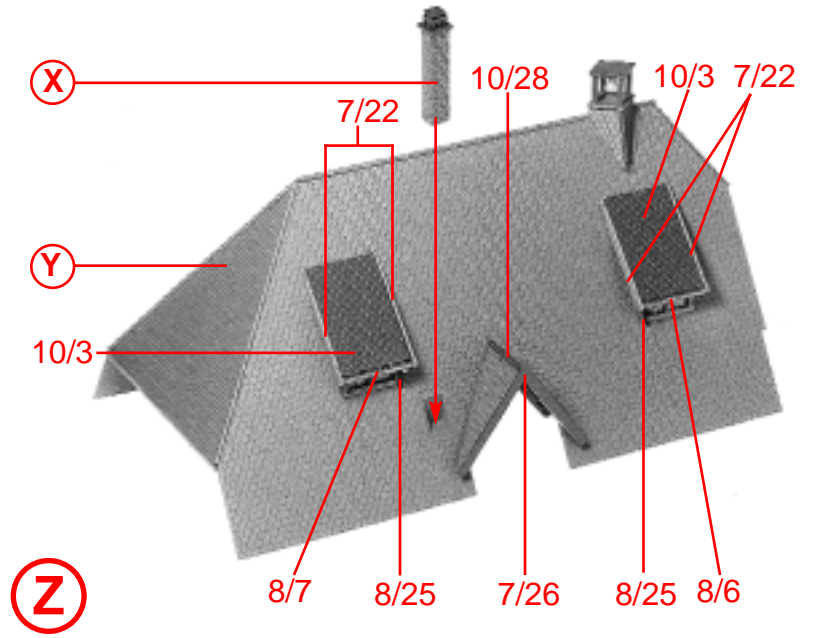
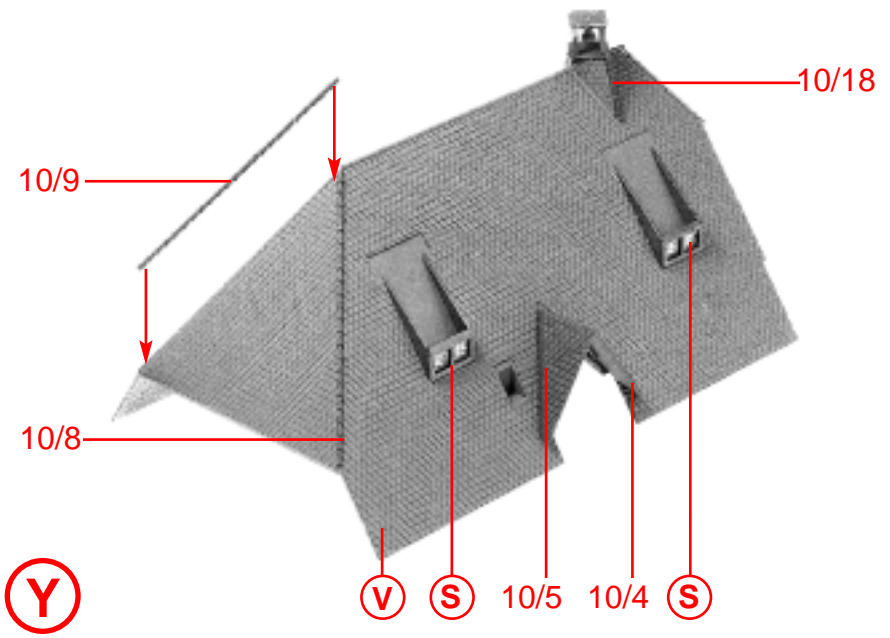
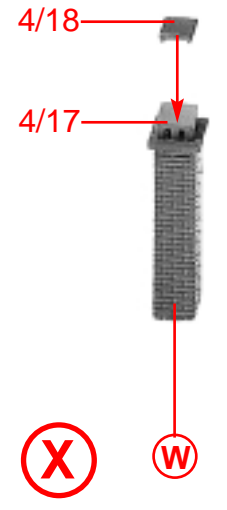
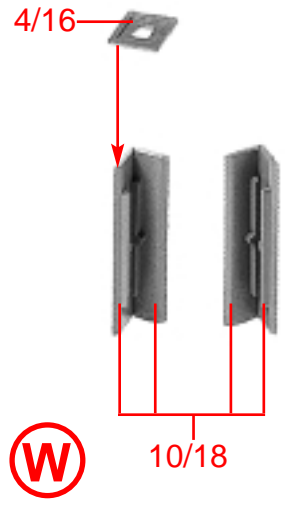
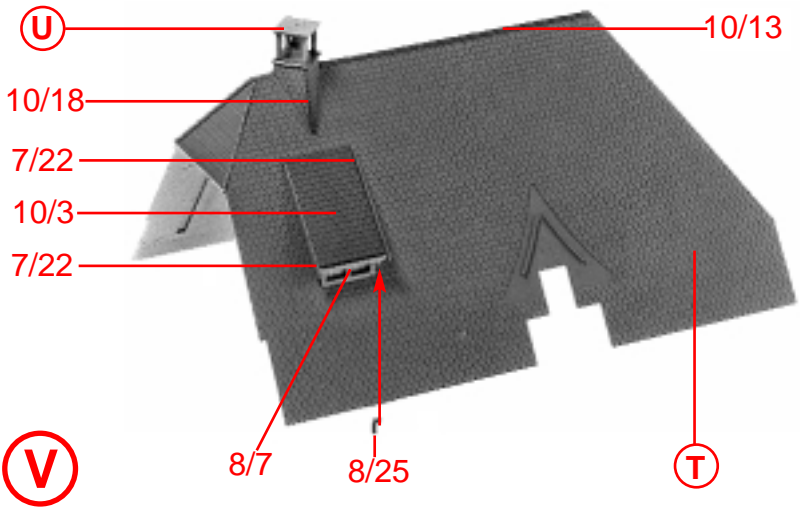
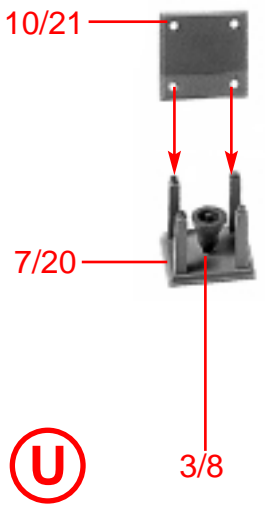

16

Spritzlinge	2	8
Sprues	6	11
Moulages	7	
Gietstukken	7	

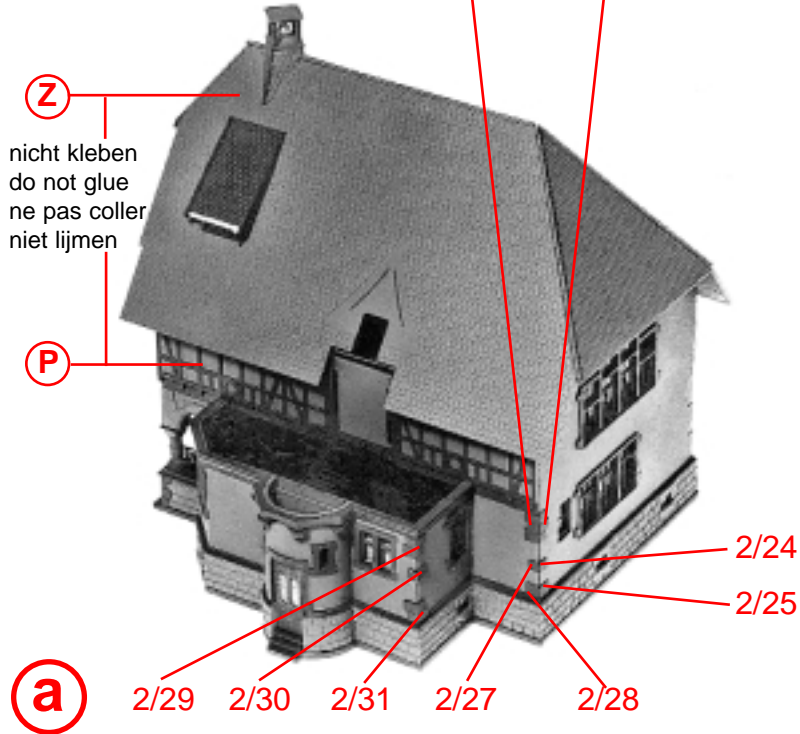

nicht kleben  
do not glue  
ne pas coller  
niet lijmen

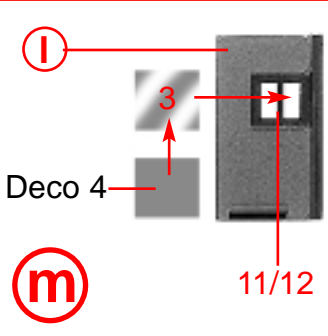
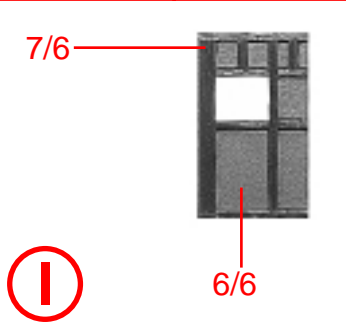
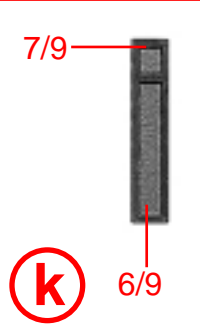
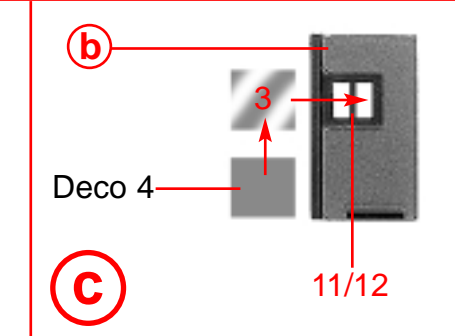
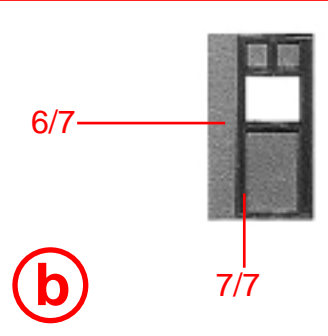
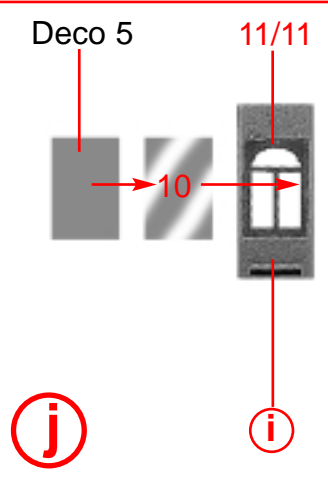
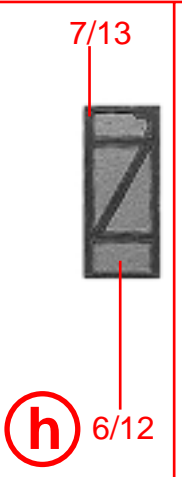
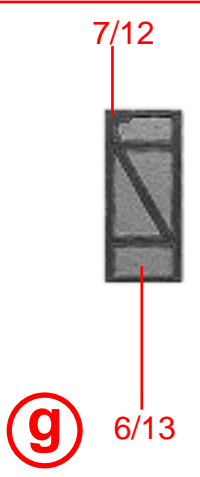
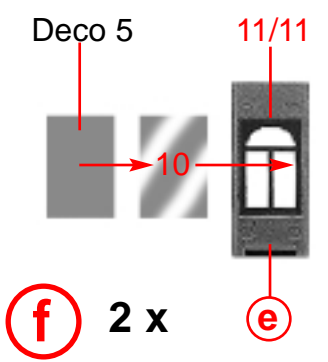
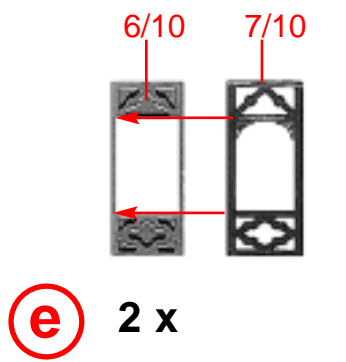



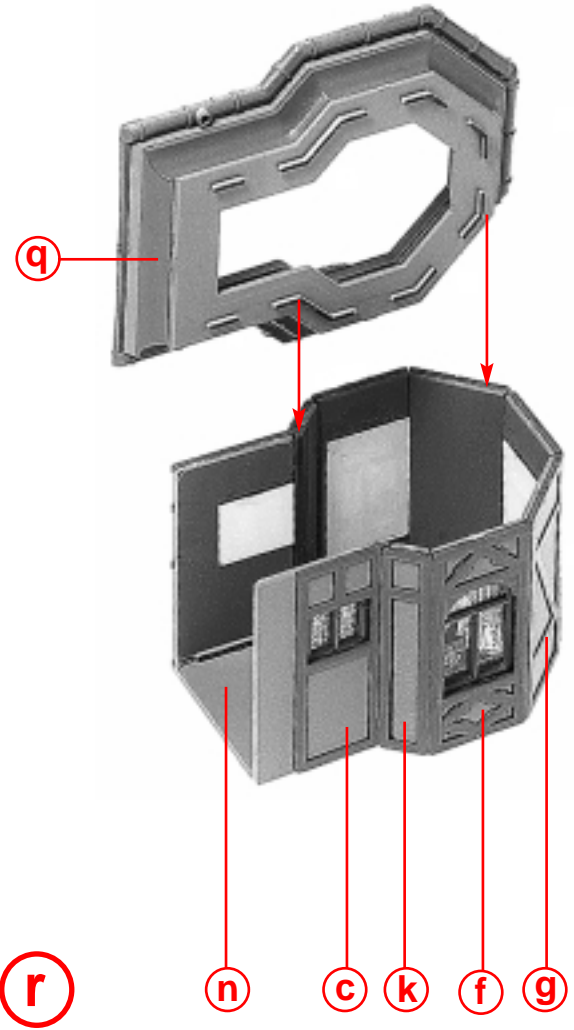
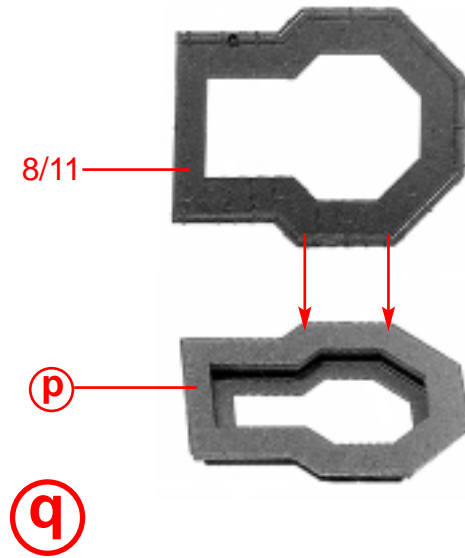
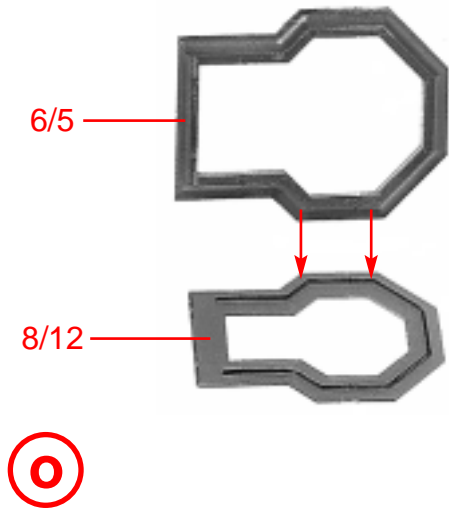
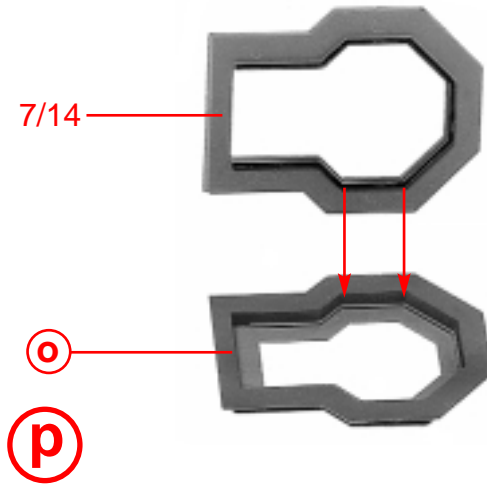
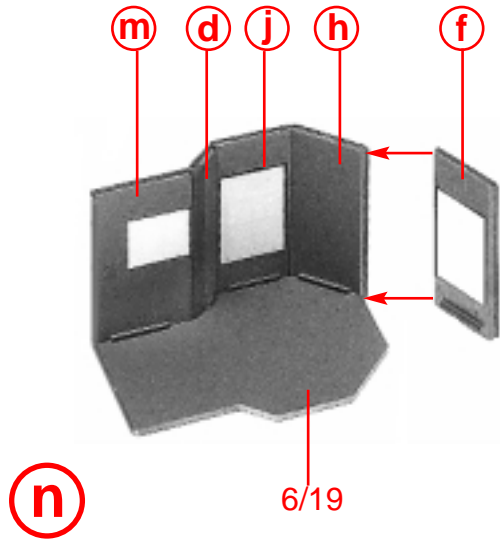

**18**

Spritzlinge	2	8
Sprues	3	10
Moulanges	7	11
Gietstukken	7	11

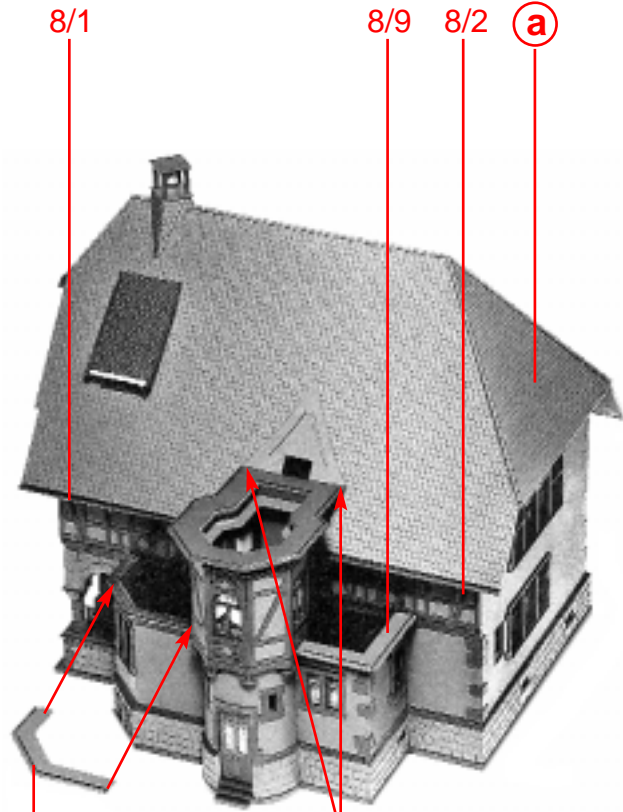

8/8

**(S)****(r)**

Nur an dieser Stelle kleben.  
 Only apply glue to this point.  
 Coller exclusivement cet emplacement.  
 Alleen op deze plaats lijmen.

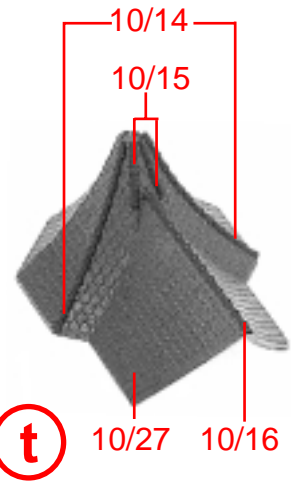
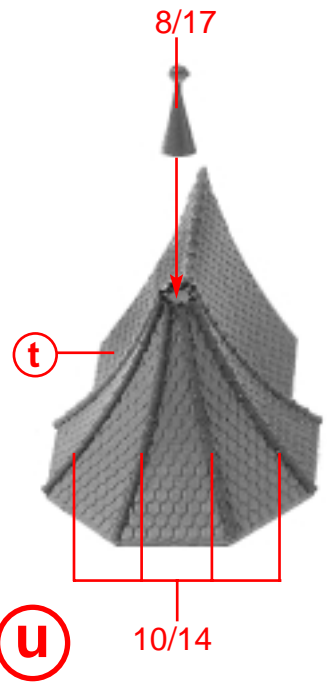
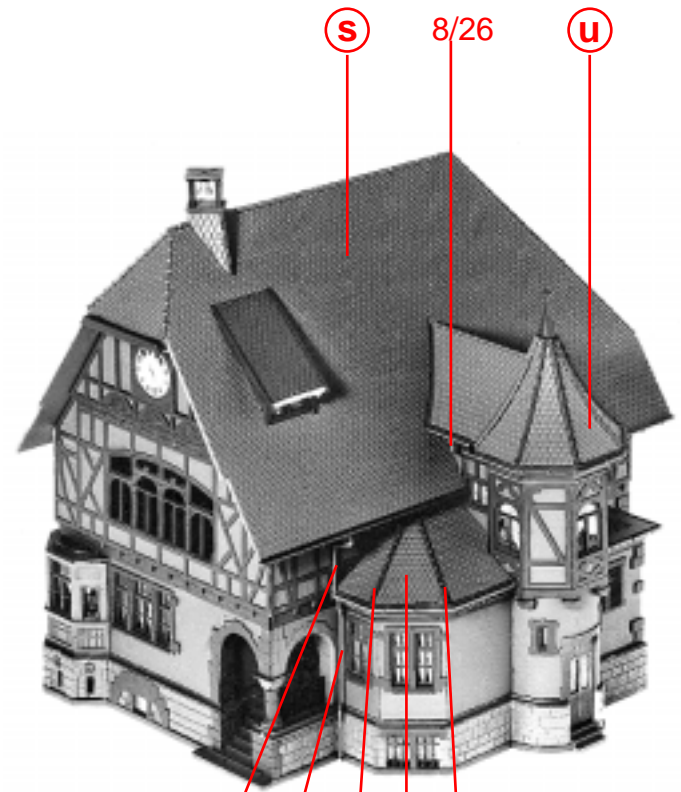
**(t)****(u)****(v)**

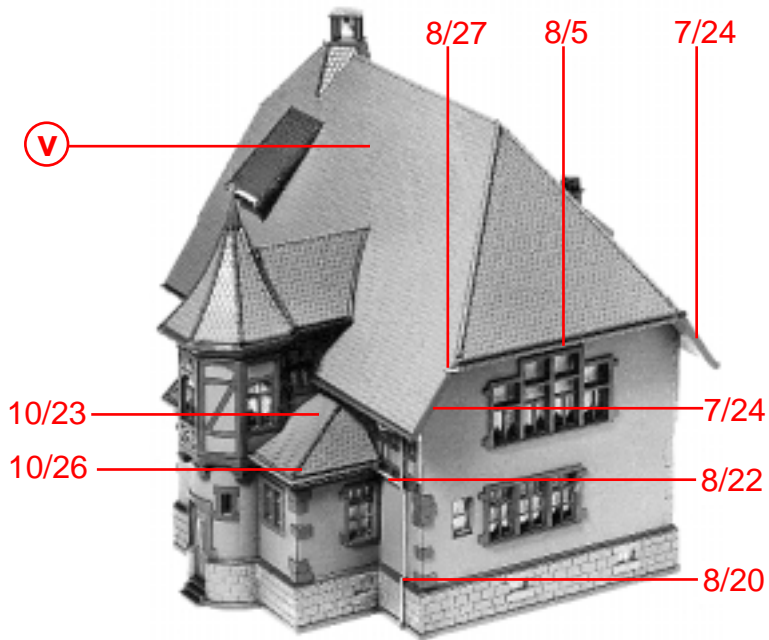

v

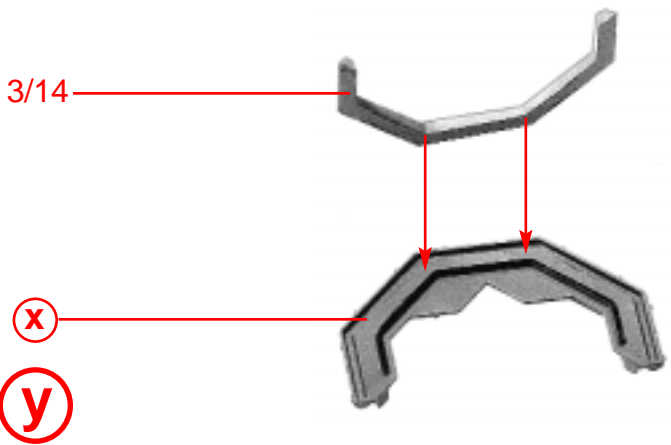

y

w

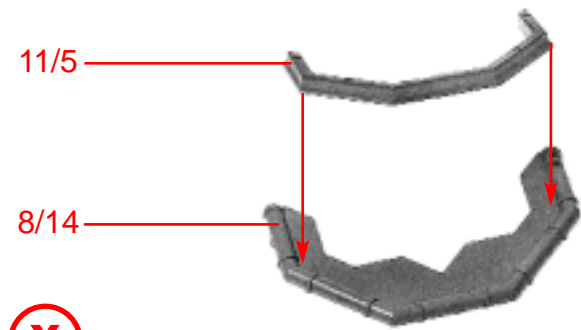

x

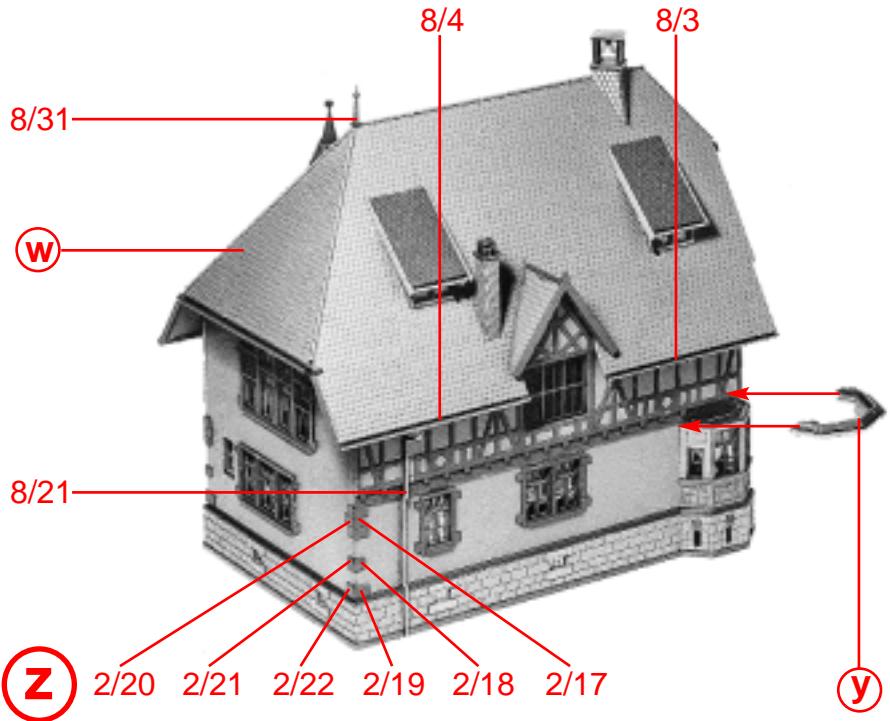

w

z

20

Spritzlinge	3	10
Sprues	7	
Moulagas	7	
Gietstukken	8	

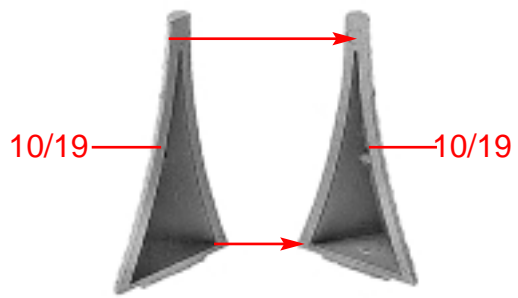
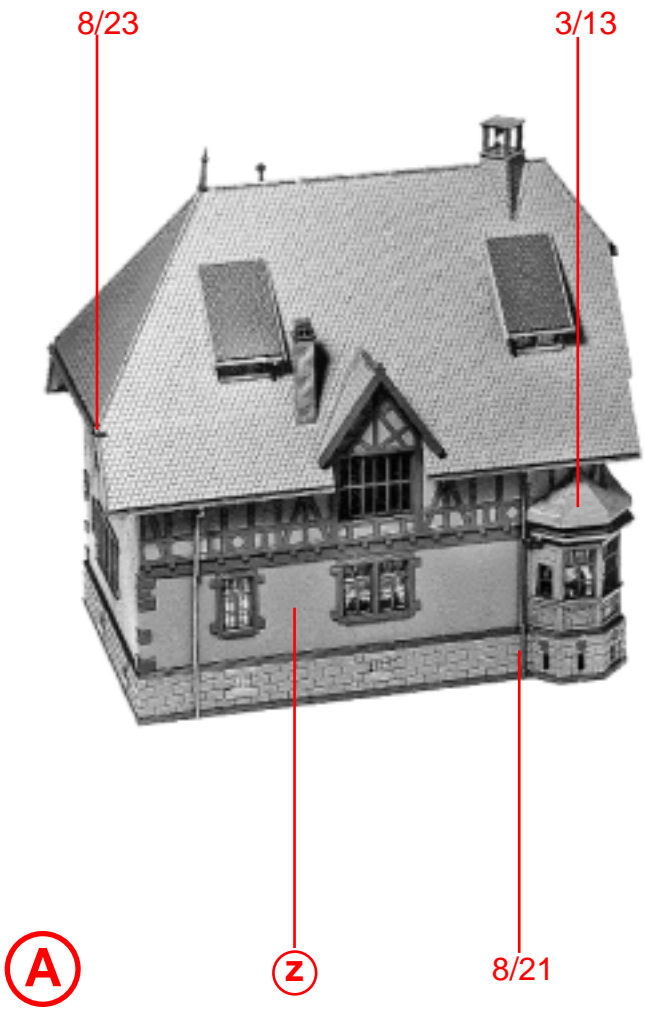

**B**

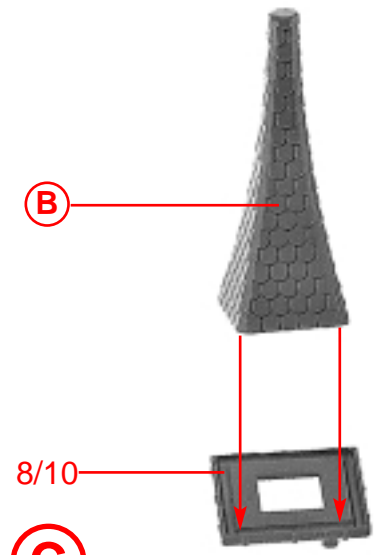

**C**

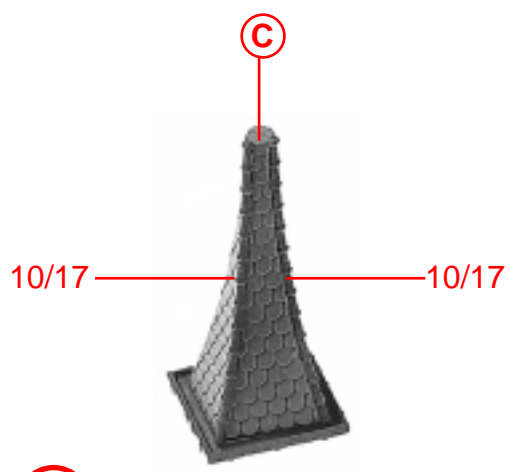

**D**

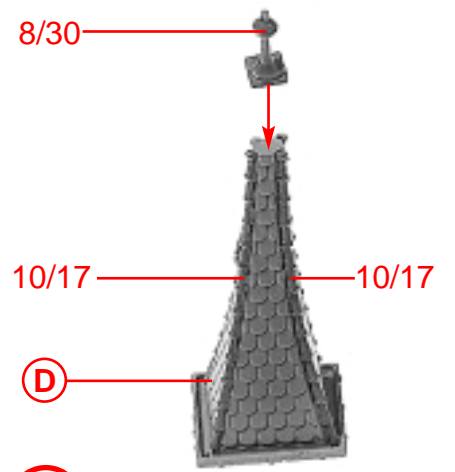

**E**

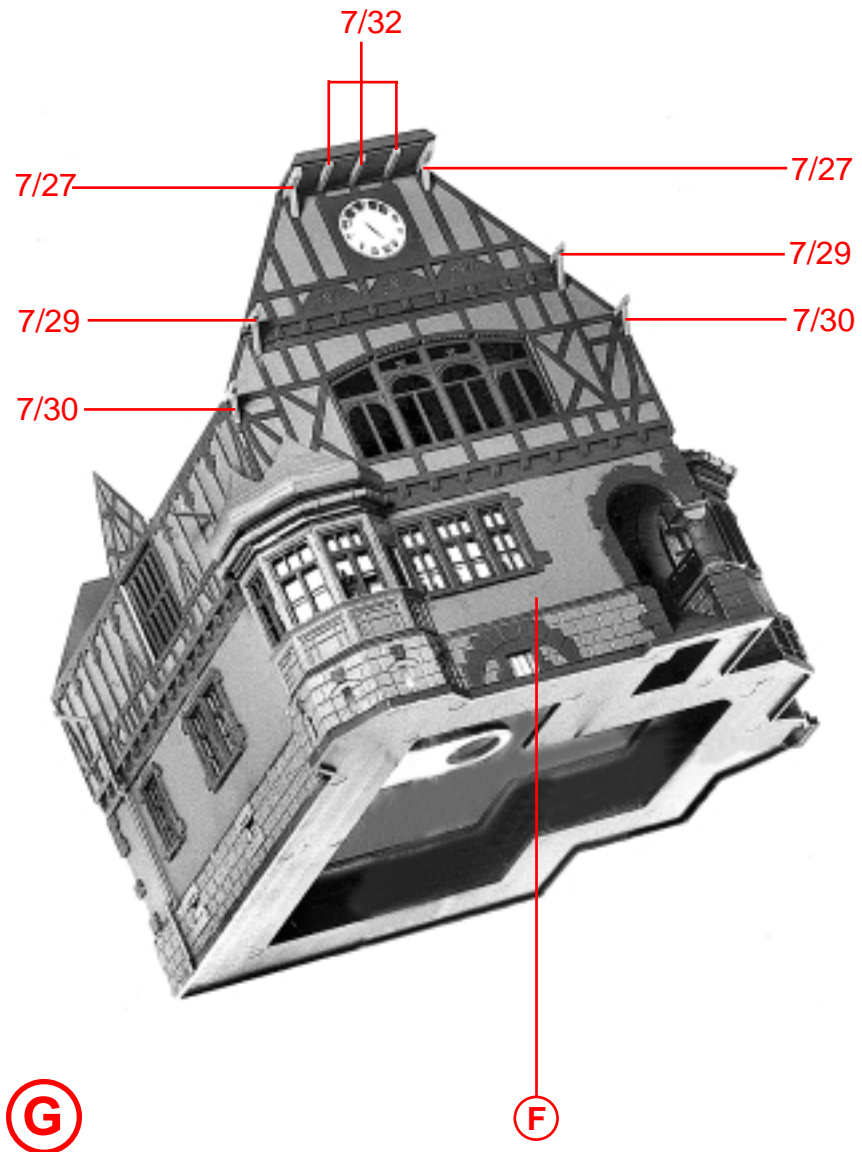
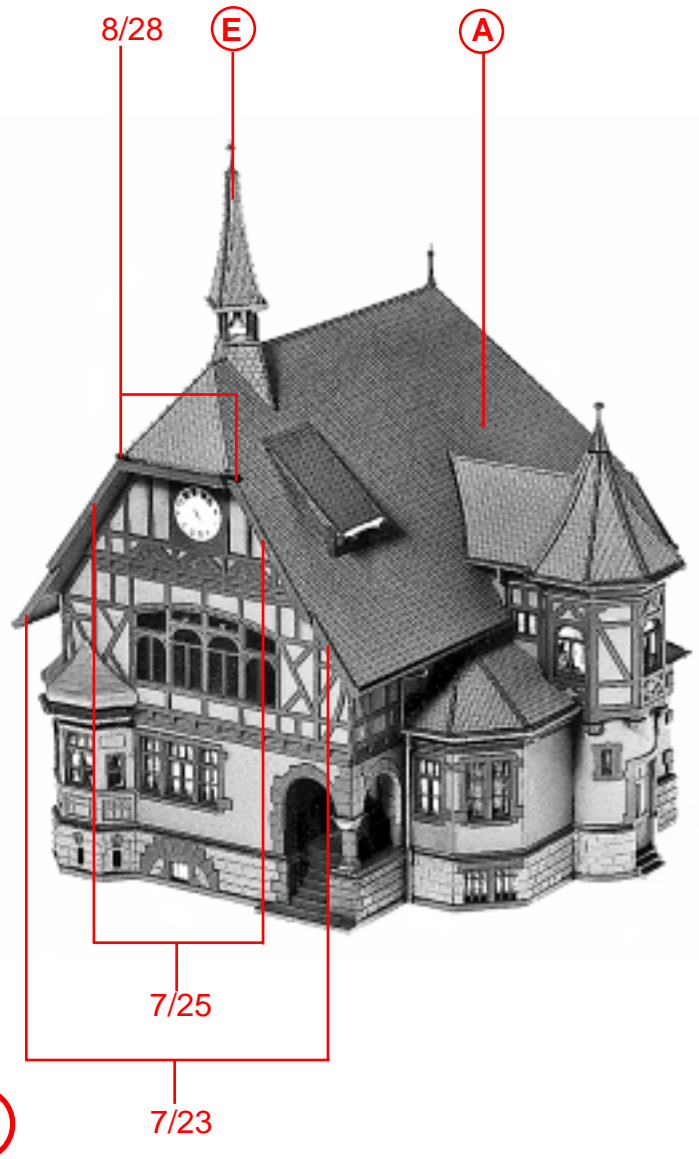

22

Spritzlinge	3
Sprues	
Moulages	7
Gietstukken	

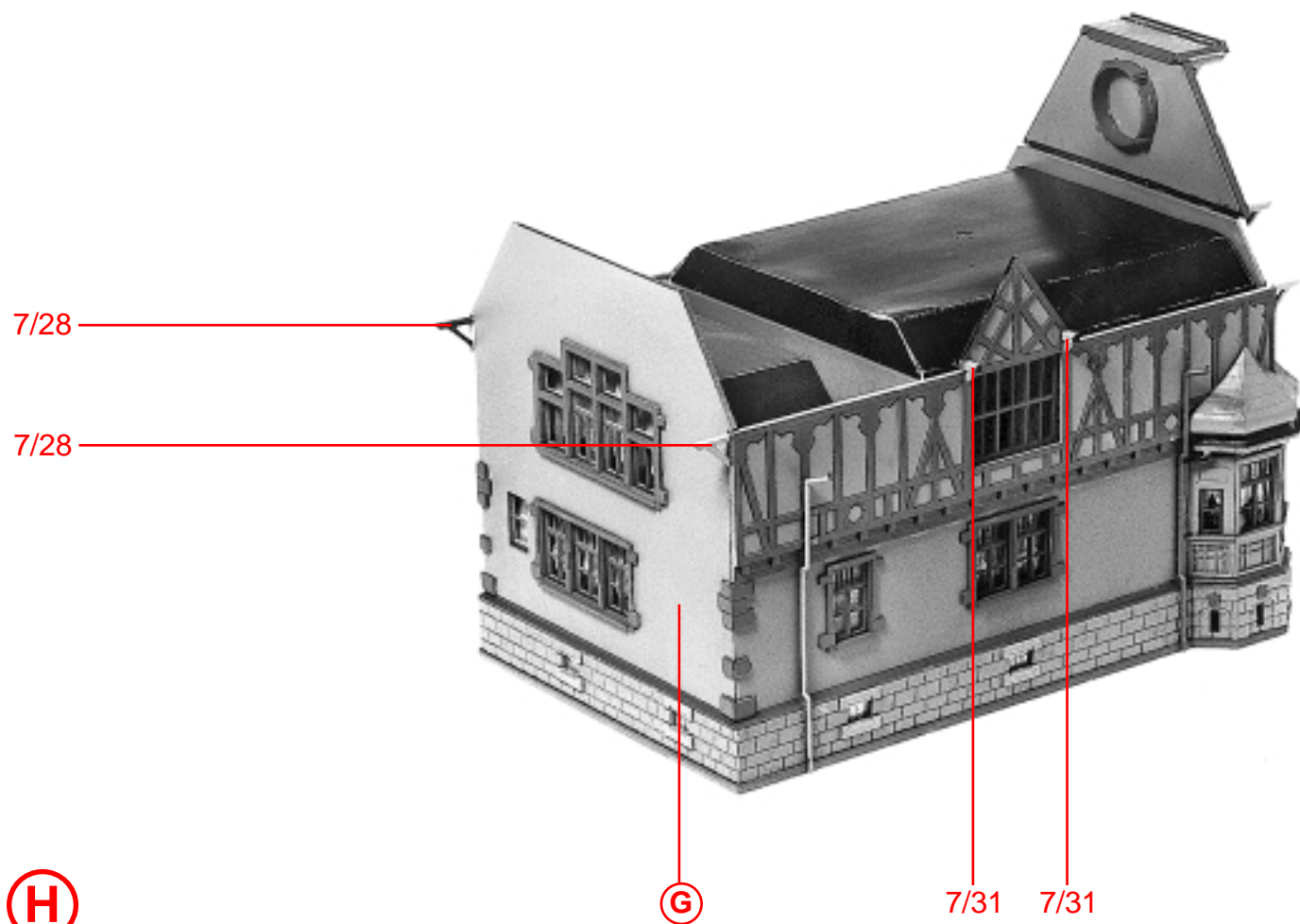

Inhalt	Tüte	Contenu	sachet
Contents	bag	Inhoud	zakje

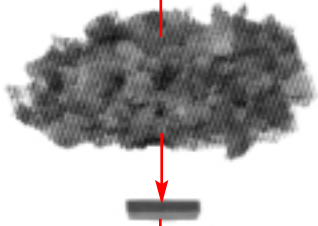

**I** 4 x 3/12

Inhalt	Tüte	Contenu	sachet
Contents	bag	Inhoud	zakje

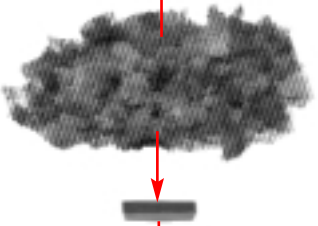

**K** 4 x 3/10

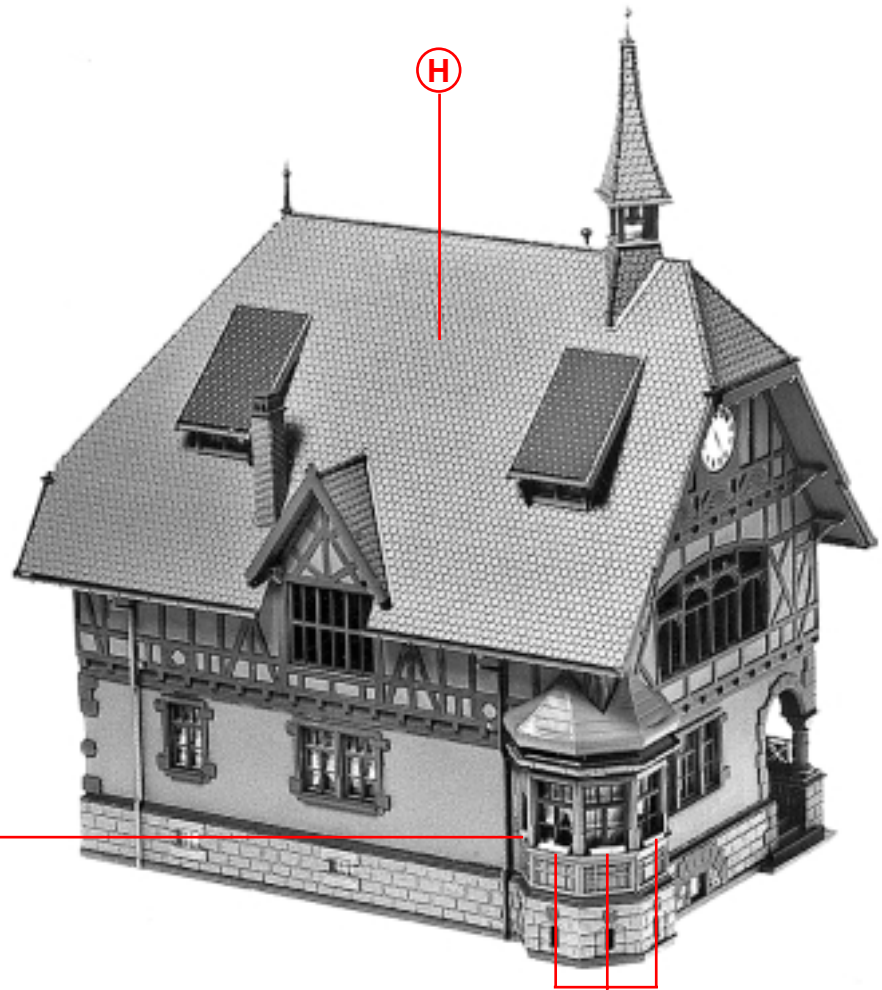

**I**

**L**

**K**

24

Spritzlinge	3
Sprues	
Moulages	
Gietstukken	

Inhalt	Tüte	Contenu	sachet
Contents	bag	Inhoud	zakje

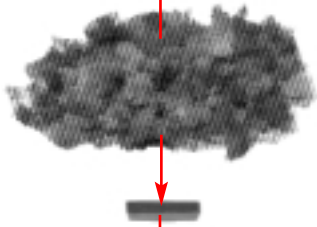

**M** 4 x 3/9

Inhalt	Tüte	Contenu	sachet
Contents	bag	Inhoud	zakje

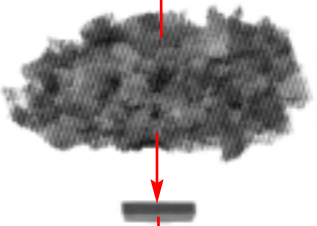

**N** 3 x 3/11

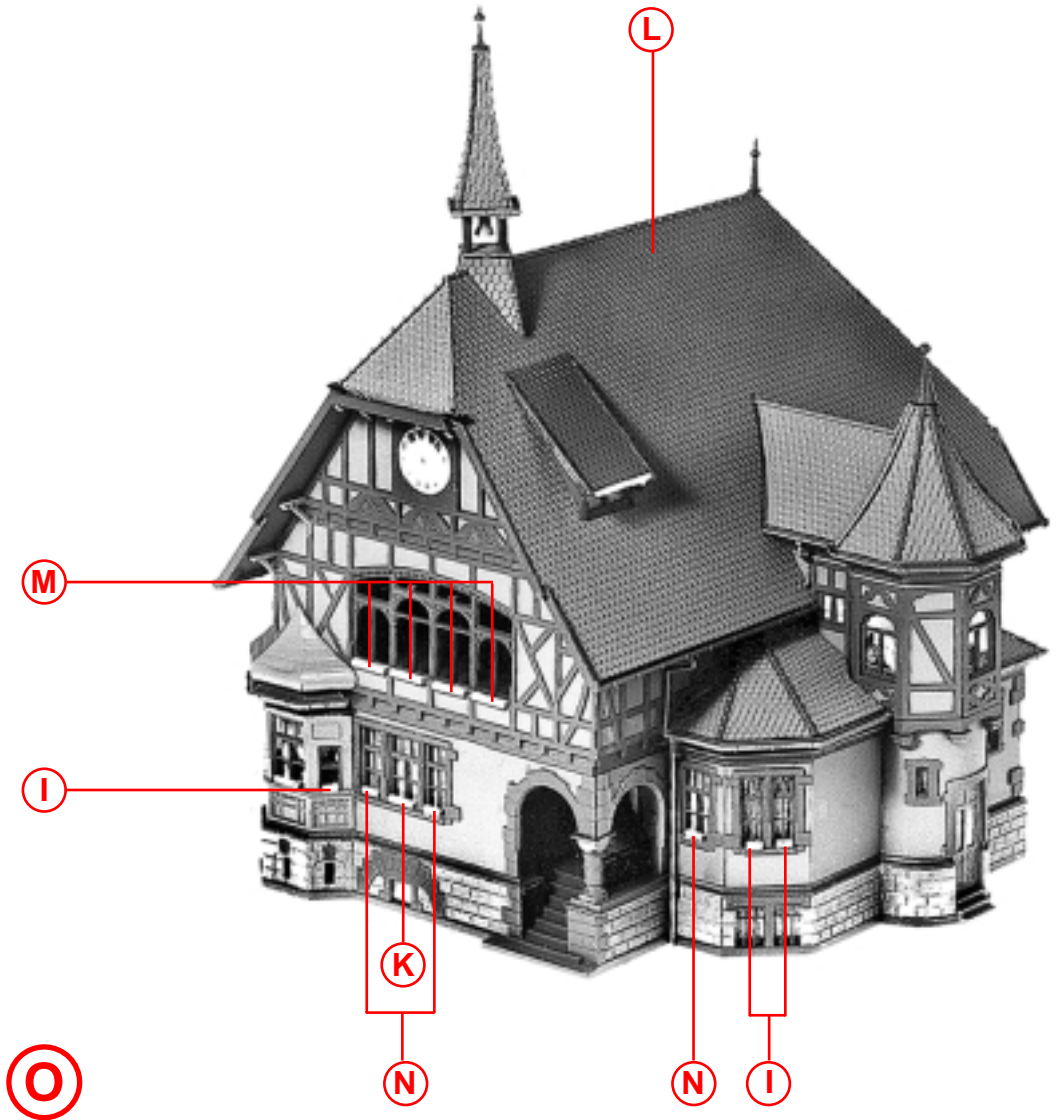

**M**

**I**

**K**

**O**

**N**

**N**

**I**

**L**