

- D**
- Vor Beginn des Bastelns sollten Sie sich mit den Spritzlingen und der Anleitung vertraut machen.
  - Sollte es einmal vorkommen, daß ein Teil im Bausatz fehlt, kreuzen Sie bitte das fehlende Teil in der Anleitung an und schicken Sie diese bitte an Fa. Gebr. FALLER GmbH, Abt. Kundendienst, Postfach 1120, 78148 Gütenbach. Sie erhalten dann umgehend Ersatz.
  - **In diesem Bausatz sind einige Kunststoffteile übrig.**

- GB**
- Before commencing with the assembly please familiarize yourself with the parts and read the instructions carefully.
  - In case of missing part(s) please indicate these on the instructions leaflet with a circle and return the leaflet to Gebr. FALLER GmbH, Postfach 1120, 78148 Gütenbach, Germany. You will receive the replacement by return.
  - **Some of the parts in this box are not needed to construct the model.**

- F**
- Avant de commencer le montage de votre maquette bien lire la notice et repérer les grappes.
  - Si une pièce manquait dans une boîte, cochez la pièce correspondante sur la notice et renvoyez la nous à Gebr. FALLER GmbH, Postfach 1120, D-78148 Gütenbach (R.F.A.). Nous vous ferons parvenir la pièce par retour.
  - **Dans cette boîte se trouvent quelques pièces qui ne seront pas utilisées pour le montage.**

- NL**
- Vóór het bouwen zou men de gietstukken en de handleiding moeten bestuderen.
  - Indien onverhoopt een onderdeel aan het bouwpakket ontbreekt, gelieve men het ontbrekende deel in de handleiding aan te kruisen en deze te zenden aan Gebr. FALLER GmbH, Postfach 1120, D-78148 Gütenbach. U ontvangt dan omgaand en gratis het ontbrekende onderdeel.
  - **Van dit bouwpakket worden enkele kunststof delen niet gebruikt.**



492  
**EXPERT**

Flüssigkleber in Plastikflasche mit Spezialkanüle für feinste Klebstoffdosierung.

Liquid cement in plastic bottle with canule for very fine dosages.

Colle liquide en bouteille plastique avec bec verseur pour un dosage précis.

Vloeibare lijm in plastic-flacon met doseerbuisje om nauwkeurig te lijmen.



688  
**Spezial-Seitenschneider**  
zum gratfreien Abtrennen von feinsten Spritzteilen. Spitze 48° abgewinkelt. Nur für Polystyrol geeignet.

**Special side cutter**  
for cutting off ultra-fine moulded parts without burrs. Tip angel 48°. Only suitable for polystyrene.

**Pince coupante spéciale**  
pour couper sans bavure les pièces miniatures moulées par injection. Pointe coudée à 48°. Uniquement appropriée pour le polystyrène.

**Speciale zijknijptang**  
voor het braamloos afknippen van de fijnste gietstukdelen. Hoek snijvlakken 48°. Alleen geschikt voor polystyreén.



<b>Inhalt</b>	Spritzlinge	<input type="checkbox"/> 1	1 x	<input type="checkbox"/> 4	1 x	<input type="checkbox"/> 7	1 x
<b>Contents</b>	Sprues	<input type="checkbox"/> 2	1 x	<input type="checkbox"/> 5	1 x		
<b>Contenu</b>	Moulages						
<b>Inhoud</b>	Gietstukken	<input type="checkbox"/> 3	1 x	<input type="checkbox"/> 6	1 x		

2

Spritzlinge	2	5
Sprues	3	6
Moulages	4	
Gietstukken	4	

4/6

2/1

3/7

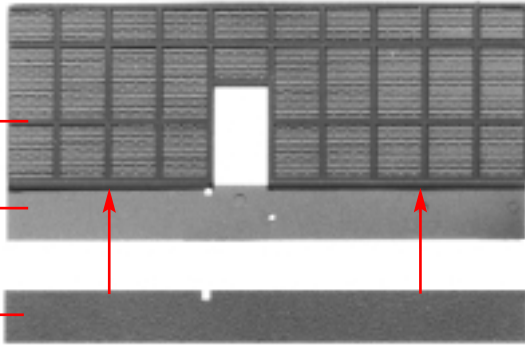

**A**

4/2

2/2

3/6

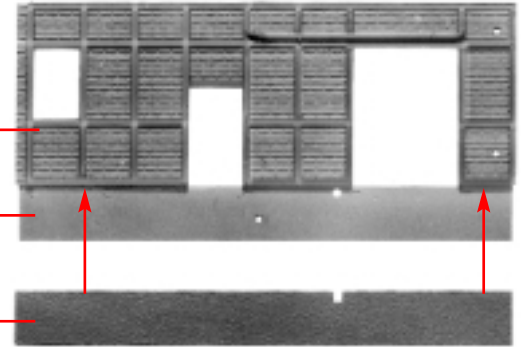

**B**



Fensterfolie  
Window foil  
Feuille fenêtre  
Raam folie

2/5

Fensterfolie  
Window foil  
Feuille fenêtre  
Raam folie

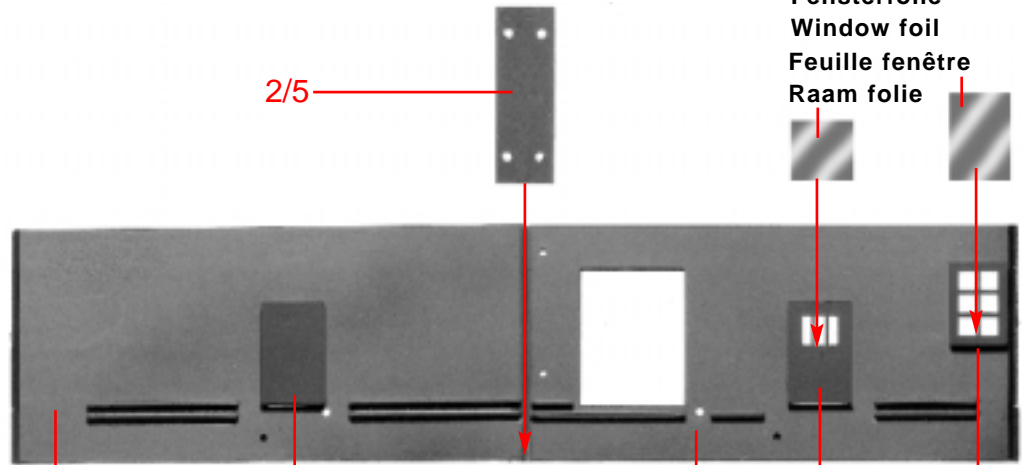

**C**

**A**

5/10

**B**

5/8

5/7

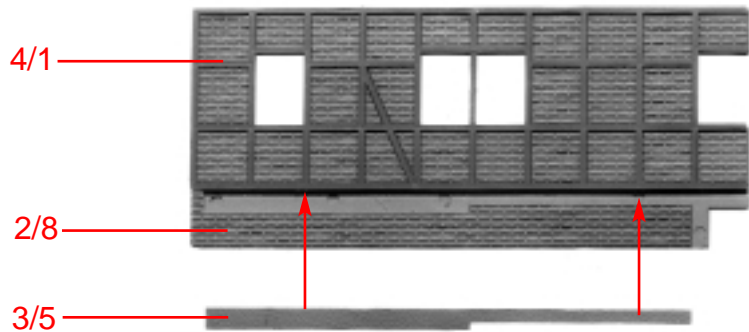

**D**

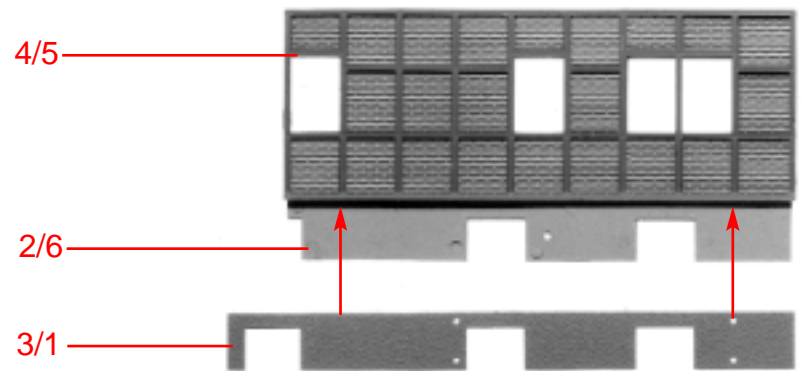

**E**

**3**

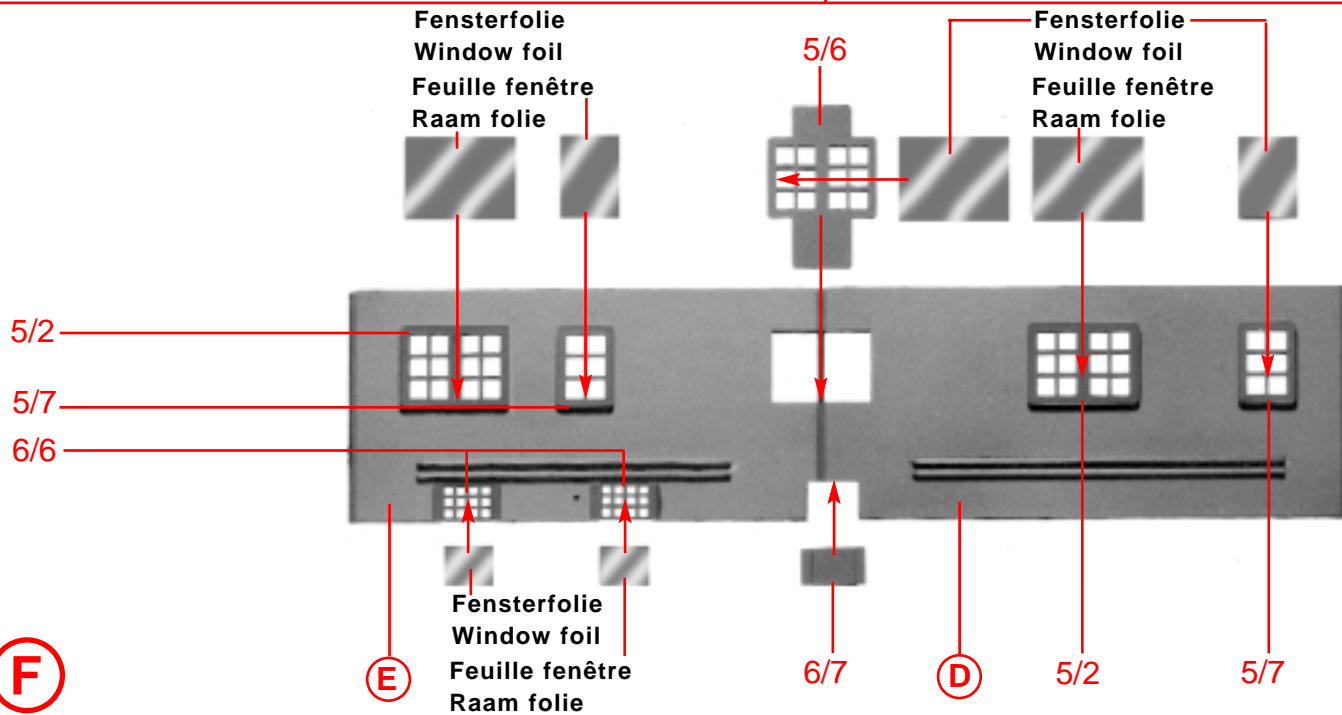

**F**

**E**

**D**

4

Spritzlinge	1	4
Sprues	2	5
Moulages	3	6
Gietstukken	3	6

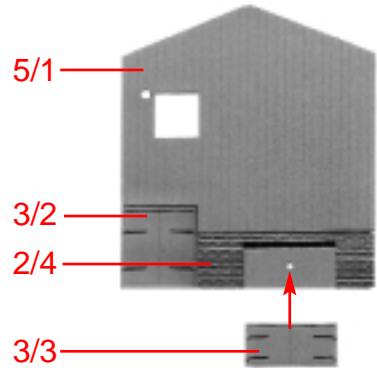

G

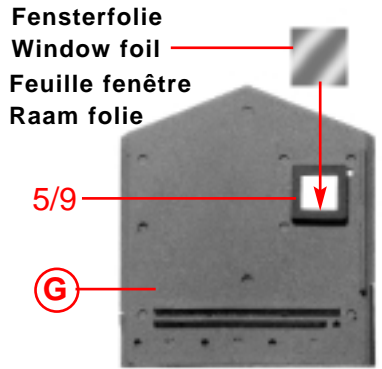

H

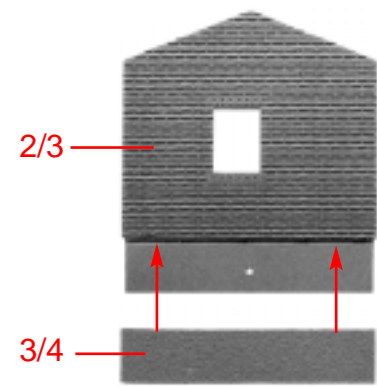

I

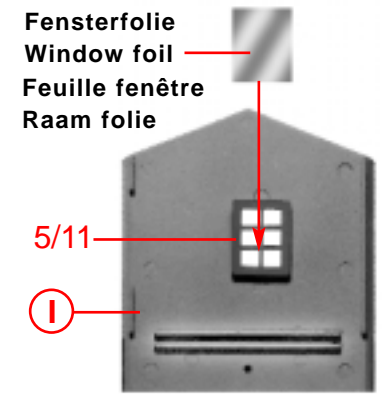

J

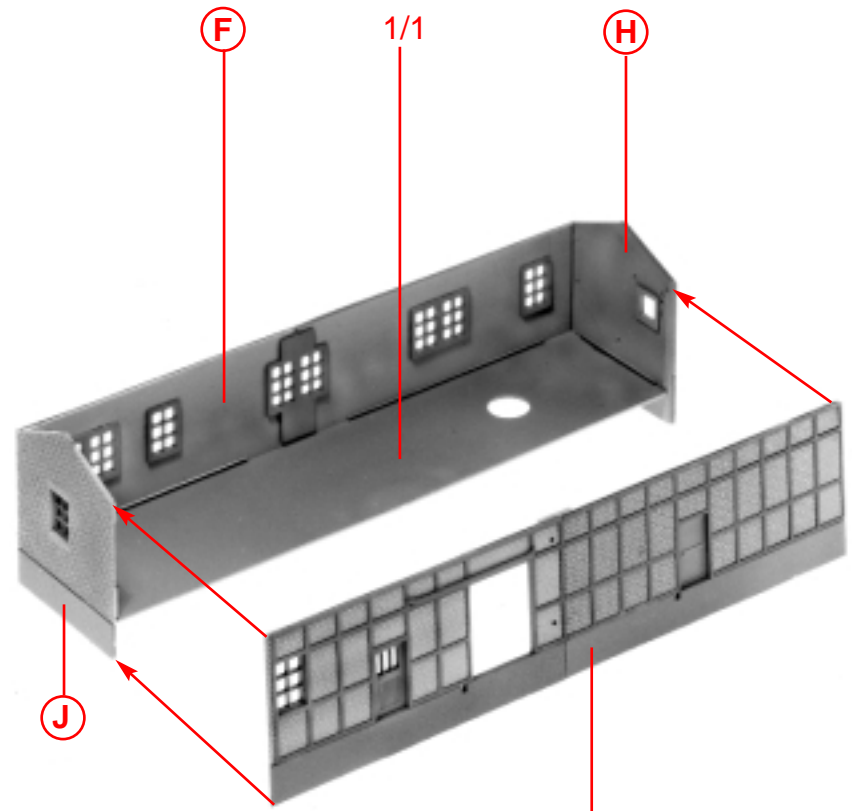

J

K

C

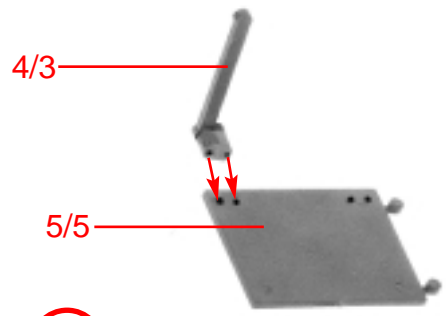

4/3

5/5

L

4/4

L

K

M

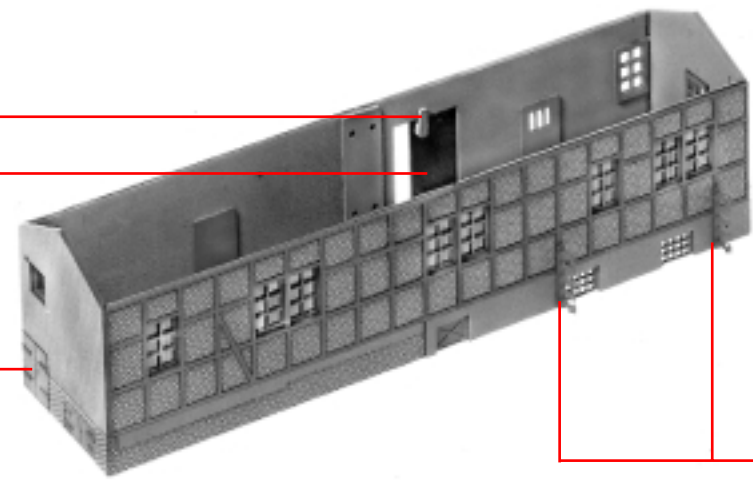

4/7

2/7

N



6/11

5/3

5/4

Fensterfolie  
 Window foil  
 Feuille fenêtre  
 Raam folie

N

O

1/3

1/2

1/4

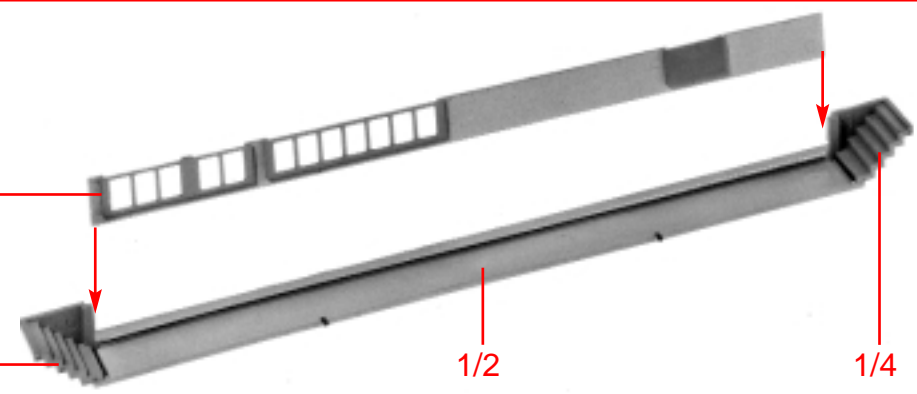

6

Spritzlinge	1
Sprues	6
Moulages	7
Gietstukken	7

Papiermaske  
papermask  
masque  
masker

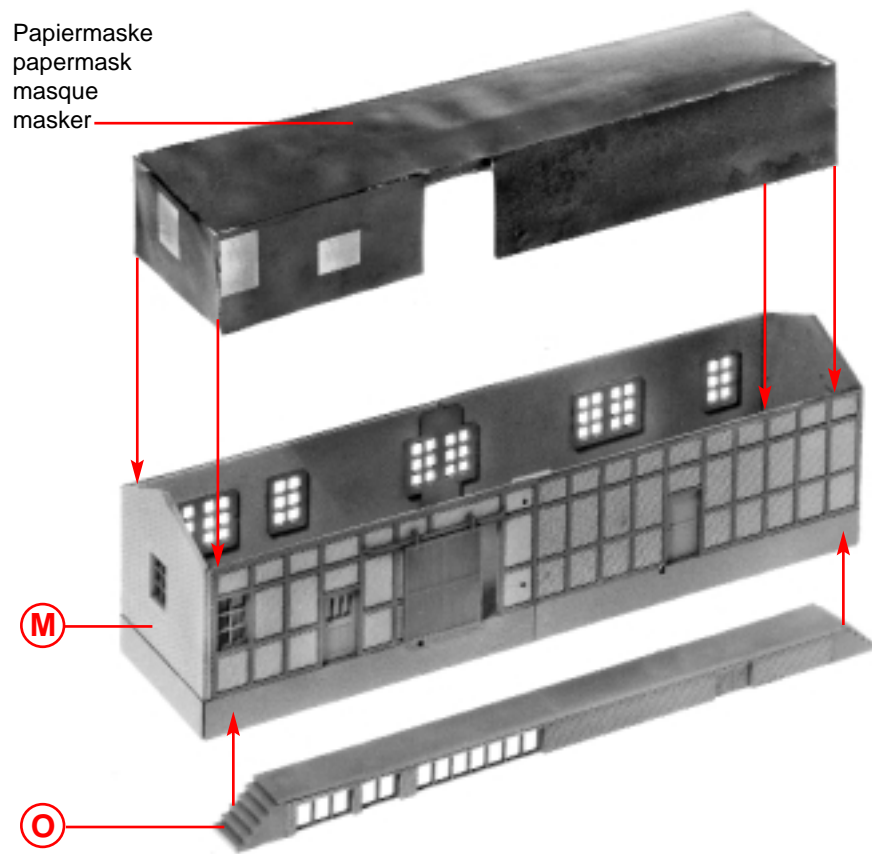

M

O

P

6/12

nicht kleben  
do not glue  
ne pas coller  
niet lijmen

1/10

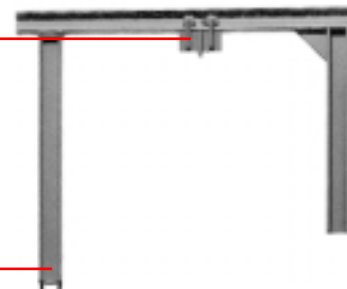

Q

Nur an dieser Stelle kleben.  
Only apply glue to this point.  
Coller exclusivement cet emplacement.  
Alleen op deze plaats lijmen.

6/16

6/13

Q

R

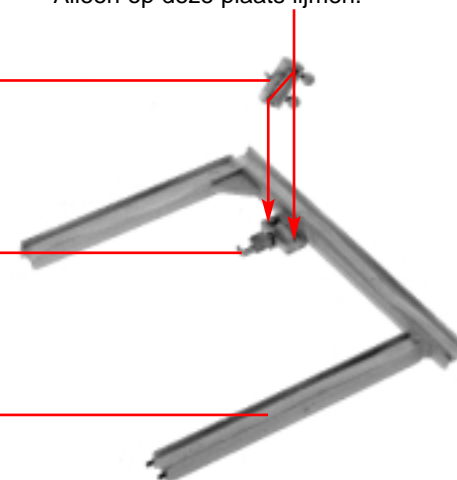

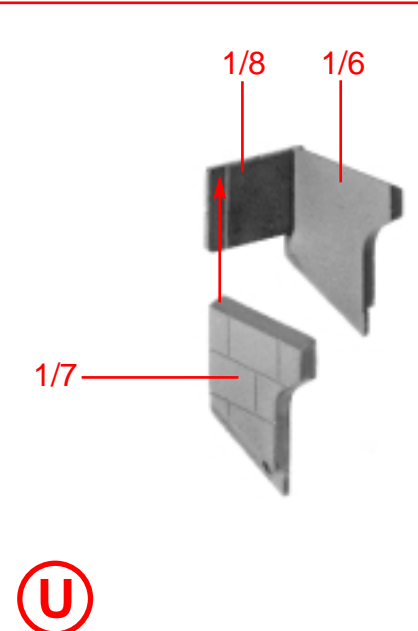
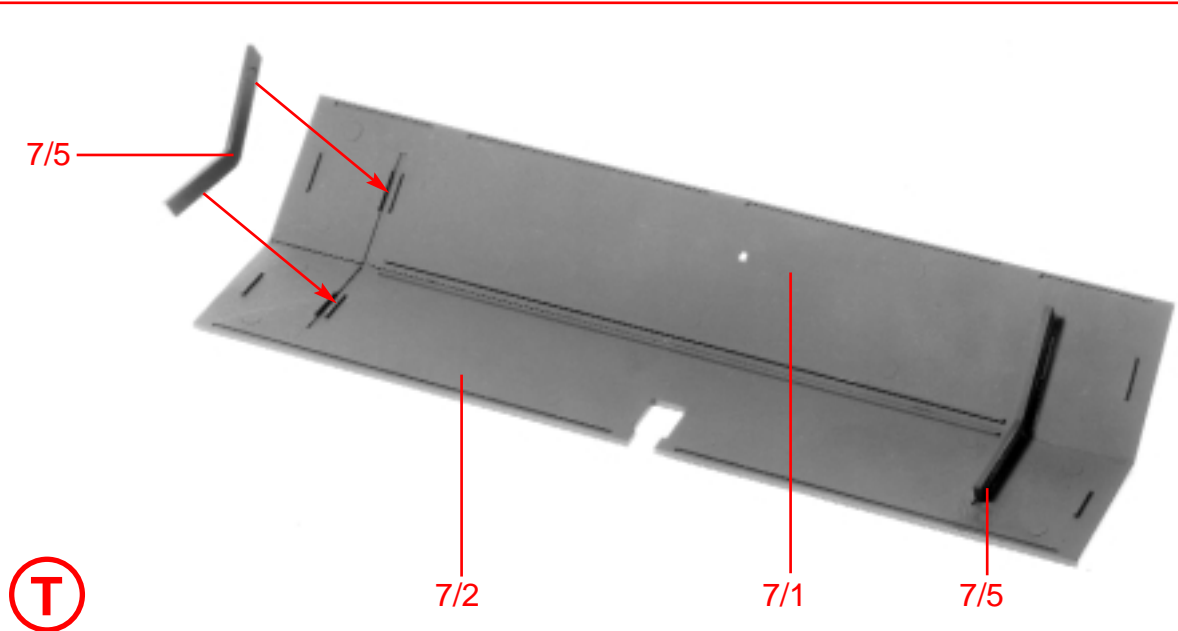
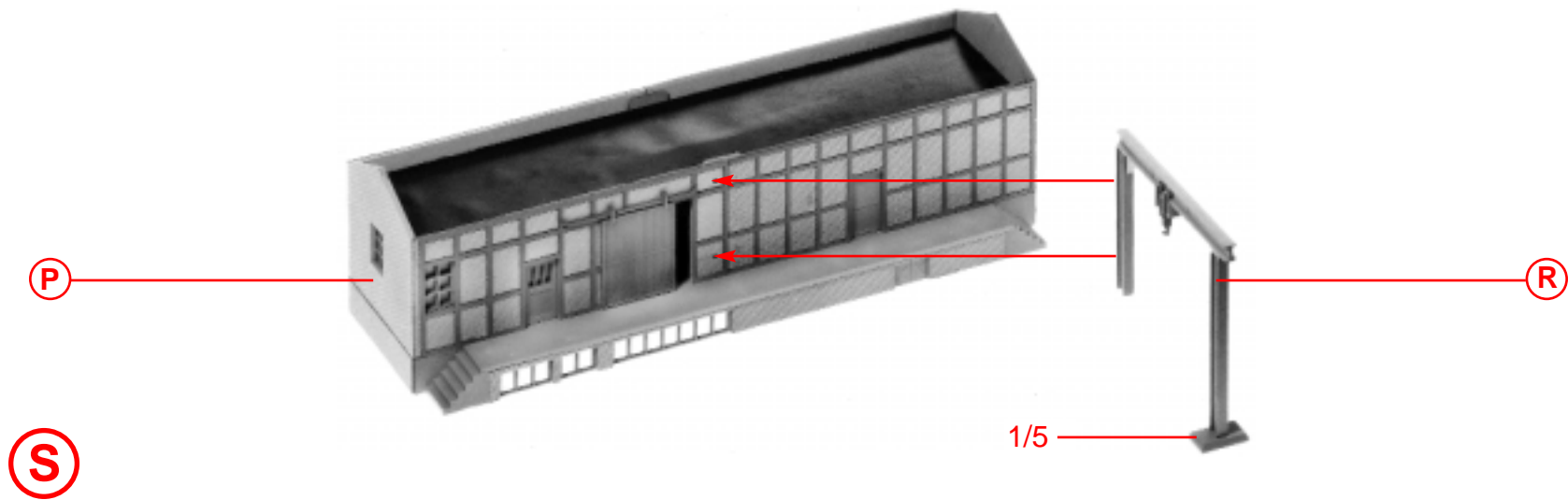

8

Spritzlinge	1
Sprues	6
Moulagas	7
Gietstukken	7

